

DA180 Series Basic AC Servo System



CE



invt

www.realtechotomasyon.com.tr



INVT DA180 Series Basic AC Servo System

DA180 series basic AC servo drive is the new generation of INVT simplified single-axis servo product. Utility oriented, making expansion easy. It provides efficient and competitive solutions for the simplification, networking and efficiency requirements of general purpose equipment.

Features:

- High dynamic response with the response frequency of 2.0kHz.
- Surging power with 3 times overload capacity.
- Internal multi-point position, homing.
- Support Modbus, CANopen, EtherCAT.
- The vibration can be controlled effectively through low frequency vibration control, disturbance control, friction torque compensation, automatic/manual notch filter.
- Automatic load inertia identifying, simple gain adjustment.
- Small and light, as you wish.



INVT DA180 Series Basic AC Servo System



Servo drive features

High-speed response

The speed response frequency can reach 2.0kHz, greatly improving the processing rate and reducing the tuning time, with the full use of advanced mechanical performance.

2.0kHz



Light appearance

Compared with DA200, the size of the DA180 drive can be reduced by 45%. It is a compact drive that can be controlled with one hand, saving installation space and making the device smaller.

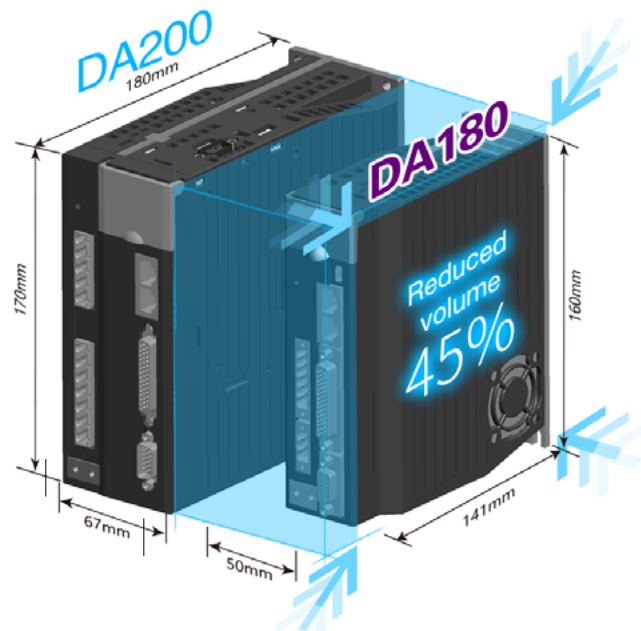

Positioning accuracy

17-bit and 23-bit absolute resolution encoders.

Enriched communication interfaces

Networking based on Modbus, CANopen, or EtherCAT achieves remote, multi-axis, highspeed, synchronous control.



Strong environmental adaptability

Natural cooling is used for 400W and lower drives.

Product features

Extremely flexible internal position control

Achieve 128-segment internal position control with combination of input terminal commands (external I/O or bus control). For simple motion control, the internal program design can help simplify the PLC unit and optimize the external configuration plan.

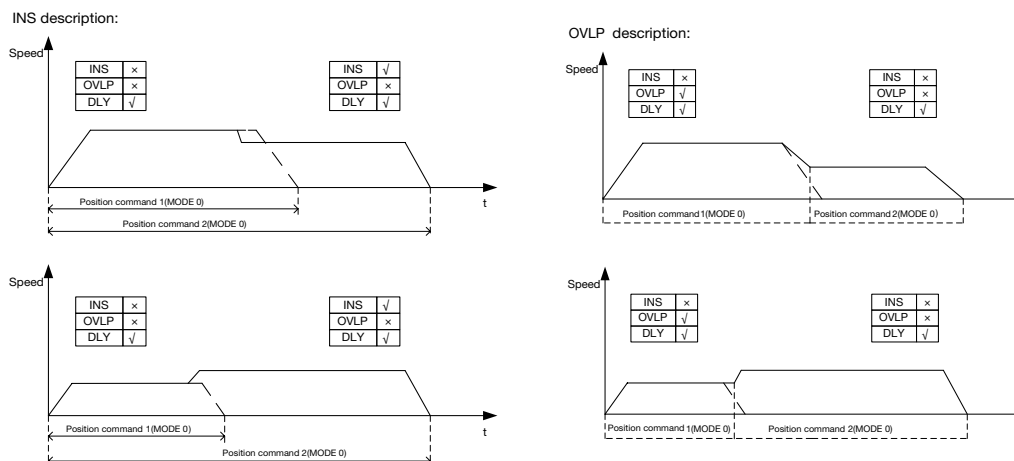

Low-frequency vibration control

Special low-frequency vibration control algorithms can be used to effectively control low-frequency mechanical resonance and control oscillation at long swing arm end, improve running efficiency, and increase running speed.

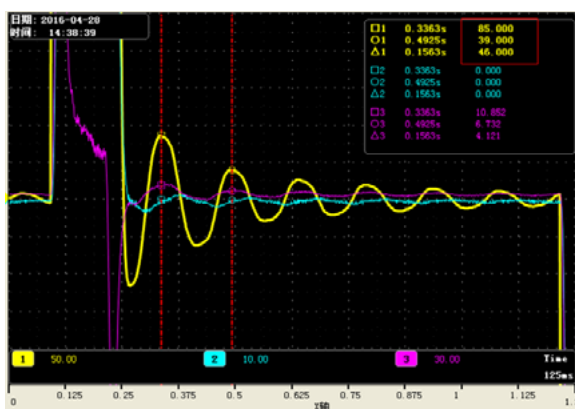
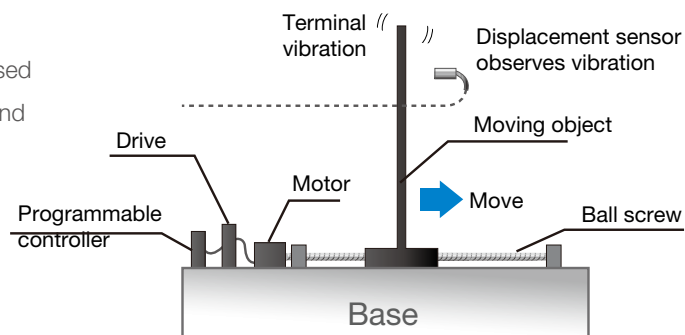

Vibration control is not conducted

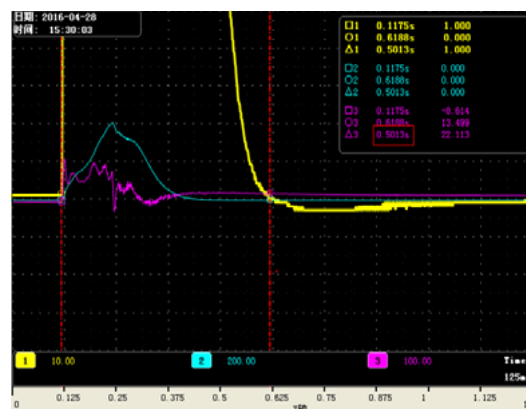

Vibration control is conducted

Product features

■ Automatic/Manual notch filter

Simplified notch filter setup achieves automatic vibration detection without vibration frequency measuring.

The notch filter can be used to significantly reduce abnormal noise and vibration caused by mechanical equipment, and further increase system rigidity to achieve better control effect.

DA180 series product carries four notch filters, each of which has frequency designated to 50Hz–5000Hz and adjustable depth. (Two of the filters can be automatically set.)

■ Disturbance control

Equipped with the disturbance control function to compensate for the control performance impact caused by load disturbance and parameter changes, enhancing system robustness and greatly improving command following performance.

■ Friction torque compensation

Equipped with the friction torque compensation function to reduce the impact caused by static friction during motor commutation and improve command following performance at low speed running.

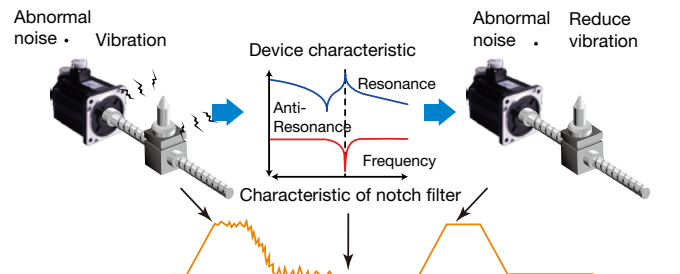

■ Load inertia identifying

Providing online and offline inertia identifying. Automatically identifying gain parameters in the system reduces system tuning time.

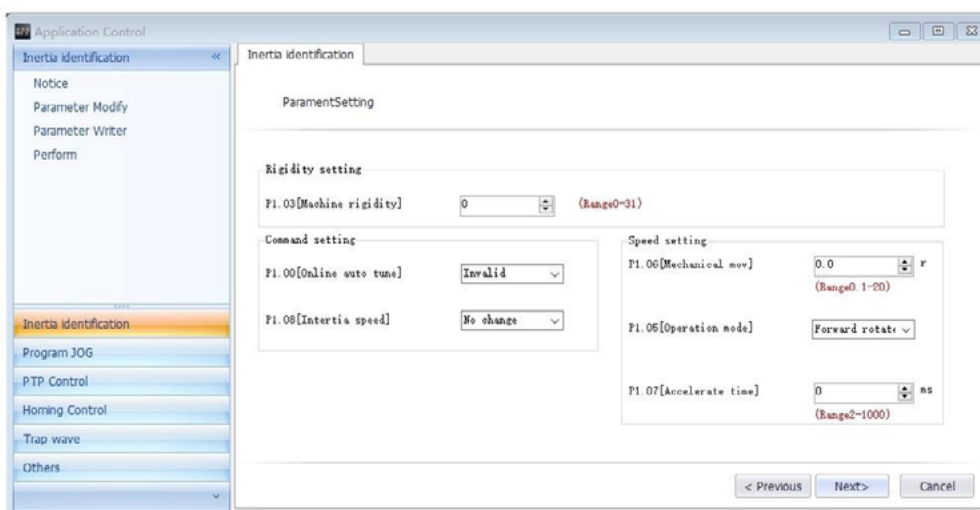

■ Simple gain adjusting and switching

The speed and position loop gains and filter time constant can be automatically adjusted by setting rigidity levels, effectively reducing commissioning complicity. Two groups of gain can be set, and the gains can be switched through I/O input, communication, or internal variables, fulfilling flexible process demands.



Product features

- User-friendly operation software, simple and intuitive, easy to use

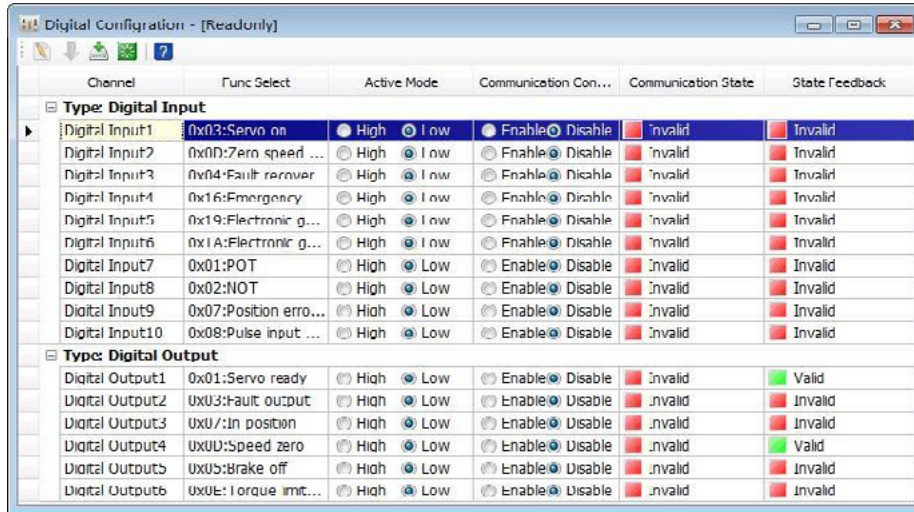

Digital I/O can directly select effective terminal logic and function distribution

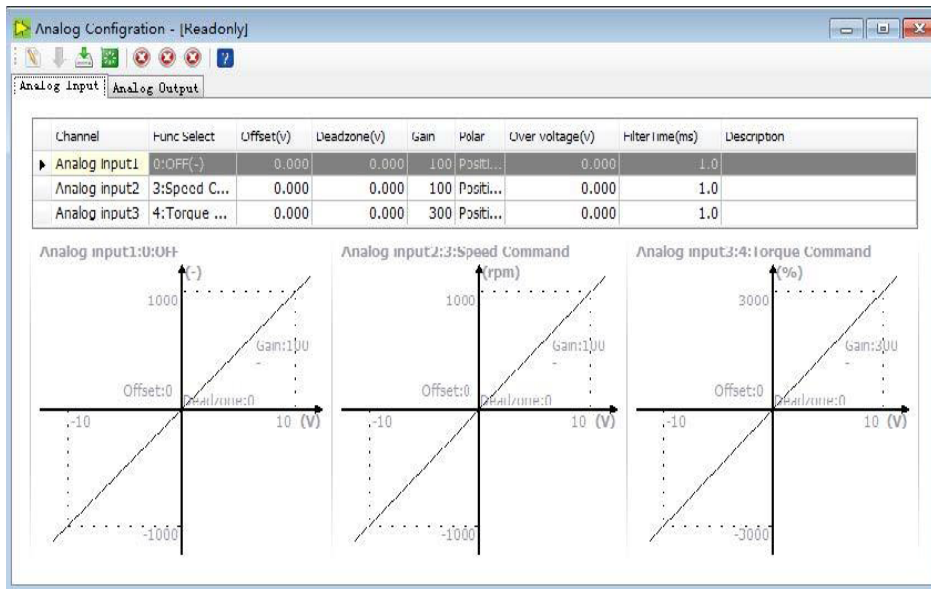

Analog input can set parameters such as gain, zero offset and deadzone, as shown above

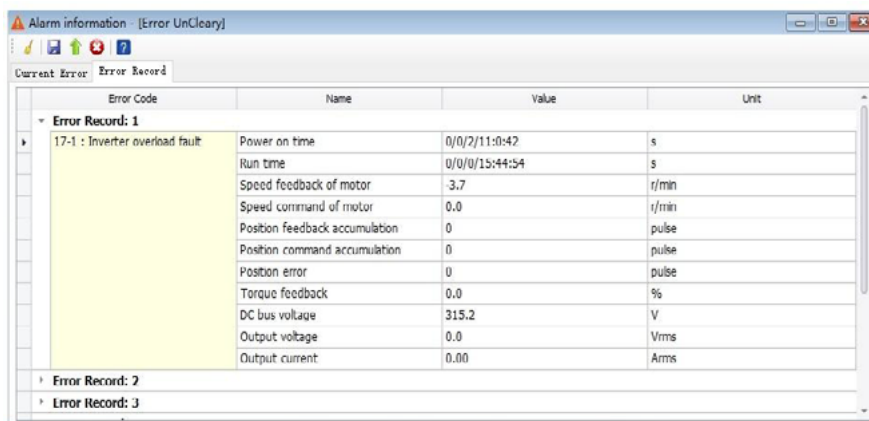

Display fault info. in real time and read fault record info.

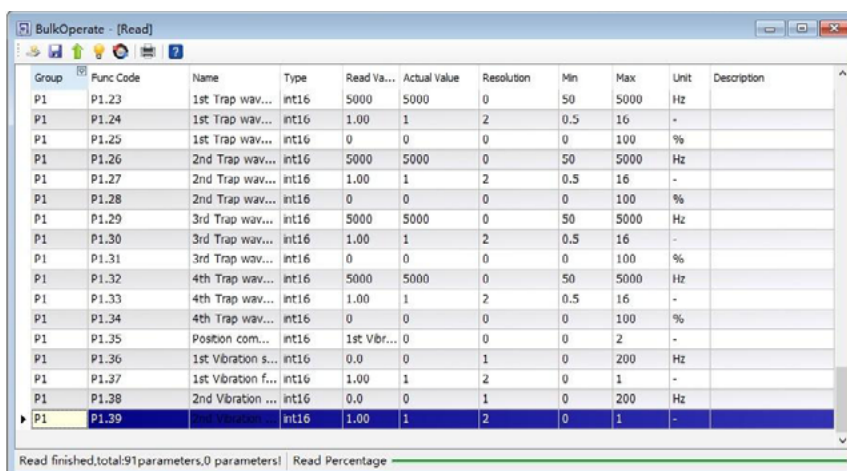

Bulk reading function can store parameters to files for easy parameter copying

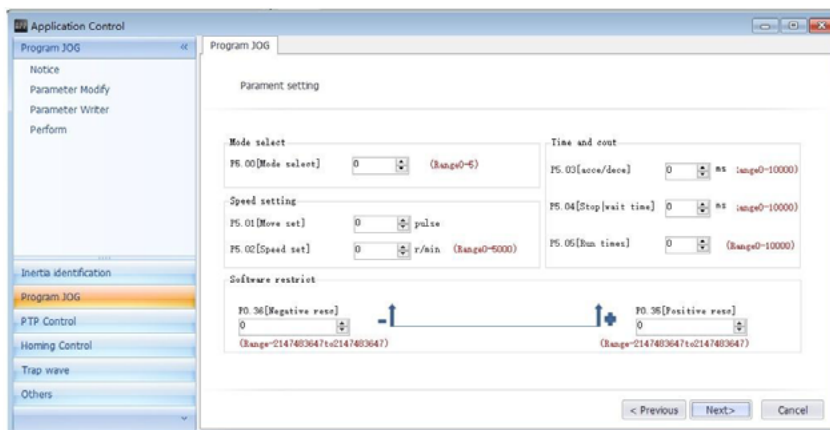

Abundant application control function for convenient pilot run and commissioning

/ Servo drive model description

DA180-S 2R8 S G 0

① ② ③ ④ ⑤ ⑥

①

Sign	Product category
DA180	Servo drive series

②

Sign	Voltage class
S	220V
T	400V

③

Sign	Rated output current
1R3	1.3A
1R8	1.8A
2R8	2.8A
3R5	3.5A
4R5	4.5A
5R0	5.0A
7R6	7.6A
010	10A

④

Sign	Communication type
S	Standard
C	CANopen bus
N	EtherCAT bus

⑤

Sign	Function category
G	Basic

⑥

Sign	Encoder type
0	Absolute type



Drive ratings and frame sizes

Model	Input		Output		Frame size
	Voltage (V)	Rated current (A)	Power (kW)	Rated current (A)	
DA180-S1R3□G0	1P 220	0.9	0.1	1.3	A
DA180-S1R8□G0	1P 220	1.8	0.2	1.8	A
DA180-S2R8□G0	1P 220	3.6	0.4	2.8	A
DA180-S4R5□G0	1P 220	6.8	0.75	4.5	B
DA180-S5R0□G0	1P 220	9.1	1.0	5	B
DA180-S7R6□G0	3P 220	5.6	1.5	7.6	C
DA180-S010□G0	3P 220	7.5	2.0	10	C
DA180-T3R5□G0	3P 400	2.1	1.0	3.5	C
DA180-T4R5□G0	3P 400	3.1	1.5	4.5	C

Brake resistor specifications

Drive model	Specification of built-in brake resistor	Min. resistance of external brake resistor
DA180-S1R3□G0	/	60Ω
DA180-S1R8□G0	/	60Ω
DA180-S2R8□G0	/	60Ω
DA180-S4R5□G0	45Ω/60W	30Ω
DA180-S5R0□G0	45Ω/60W	30Ω
DA180-S7R6□G0	30Ω/60W	20Ω
DA180-S010□G0	30Ω/60W	20Ω
DA180-T3R5□G0	60Ω/60W	60Ω
DA180-T4R5□G0	60Ω/60W	60Ω

EMI filter models

Drive model	EMI filter model
DA180-S1R3□G0	FLT-P04006L-B
DA180-S1R8□G0	
DA180-S2R8□G0	
DA180-S4R5□G0	FLT-P04016L-B
DA180-S5R0□G0	
DA180-S7R6□G0	
DA180-S010□G0	FLT-P04006L-B
DA180-T3R5□G0	
DA180-T4R5□G0	

Drive dimensions

Note: The EMI filter models in the table are INVT models. The EMI filter is used at the power input end.

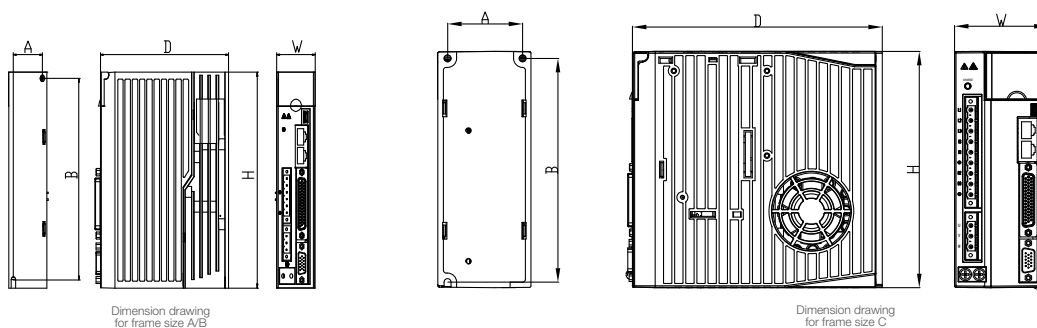

Drive frame size	Drive model	Outline dimensions			Installation dimensions		Installation hole (mm)
		H(mm)	W(mm)	D(mm)	A(mm)	B(mm)	
A	DA180-S1R3□G0	160	42	141	32	150	M4(Φ5)
	DA180-S1R8□G0						
	DA180-S2R8□G0						
B	DA180-S4R5□G0	160	50	141	40	150	M4(Φ5)
	DA180-S5R0□G0						
C	DA180-S7R6□G0	170	68	180	54	161	M4(Φ5)
	DA180-S010□G0						
	DA180-T3R5□G0						
	DA180-T4R5□G0						

Servo drive technical parameters

DA180 series servo drive (100W–2kW)				
Specification		Description		
Power supply	220V system input voltage	1/3PH,AC 220V(±15%),47-63Hz		
	400V system input voltage	3PH,AC 400V(±15%),47-63Hz		
Port	Control signal	Input	10 inputs (The function is configurable through parameter settings.)	
		Output	4 outputs (The function is configurable through parameter settings.)	
	Analog	Input	Two 12-bit analog inputs	
	Pulse signal	Input	1 input (mode: differential input or open collector)	
		Output	1 output (mode: differential output (A+, A-; B+, B-; Z+, Z-))	
	Communication	USB	1:1 communication upper computer software	
		RS485	1:n communication	
		CANopen	1:n communication (optional)	
		EtherCAT	1:n communication (optional)	
	Control mode		1: Position control; 2: Speed control; 3: Torque control; 4: Switching between the position and speed modes; 5: Switching between the speed and torque modes; 6: Switching between the position and torque modes; 7: CANopen mode; 8: EtherCAT mode	
Function	Position control	Control input	1: Clearing residual pulses; 2: Inhibiting command pulse input; 3: Switching electronic gear ratios 4: Switching vibration control	
		Control output	Such as positioning completion output	
		Pulse input	Max. pulse input frequency	Photoelectric coupling: differential input of 4Mpps or open collector input of 200kpps
			Pulse input mode	1: Pulse + direction (Pulse+Sign); 2: Clockwise + counterclockwise (CW + CCW); 3: Orthogonal coding (QEP)
			Electronic gear	1/10000~1000
		Filter	1. Command smoothing filter; 2. FIR filter	
		Analog input	Torque limit	This allows independent CW or CCW torque limit.
		Vibration control	This can suppress 5Hz–200Hz front-end vibration and entire-machine vibration.	
		Pulse output	1: This allows arbitrary frequency division settings under the encoder resolution; 2: This supports phase-B reserving.	

DA180 series servo drive (100W-2kW)				
Specification		Description		
Function	Speed control	Control input	1: Internal command speed 1; 2: Internal command speed 2; 3: Internal command speed 3; 4: Zero-point clamping	
		Control output	Such as speed reaching	
		Analog input	Speed command input	You can enable speed command inputs after performing relevant settings based on the analog voltage DC±10V.
			Torque limit input	This allows independent CW or CCW torque limit.
		Internal speed command	The internal eight-step speeds can be switched based on external control inputs.	
		Speed command ACC/DEC adjustment	This supports both independent ACC/DEC time setting and S-curve ACC/DEC setting.	
		Zero-point clamping	First-order delay filter of the analog input speed command.	
		Speed command filter	Zero-drift suppression on external interference.	
	Torque control	Control input	Such as zero-drift clamping input.	
		Control output	Such as speed reaching.	
		Analog input	Torque command input	This allows gain and polarity settings based on analog voltage.
			Speed limit input	This allows analog speed limits.
		Speed limit	Speeds can be limited through parameter settings.	
		Torque command filter	First-order delay filter of the analog input torque command.	
		Torque command zero-drifts uppression	Zero-drift suppression on external interference.	
	Internal position planning	Segment planning	This supports 128-segment internal position planning. The positioning can be controlled through communication.	
		Route setting	1: Position; 2: Speed; 3: ACC time; 4: DEC time; 5: Stop timer; 6: Status output; 7: Running mode	
		Homing	1: LS signal; 2: Phase-Z signal; 3: LS signal + phase-Z signal; 4: Torque limit signal	
Protection	Hardware protection Software protection		Overvoltage, undervoltage, overcurrent, overspeed, overload, brake resistor overload, encoder fault, etc. Storage fault, initialization fault, I/O distribution error, drive overheating, position deviation is too large, etc.	
	Fault record		1. Ten faults can be recorded. 2. Key parameters can be recorded when a fault occurs.	
	Environment	Temperature	Working temperature	0~45°C
Storage temperature			-20~80°C (no freezing)	
Working/storage humidity		≤90%RH (no condensation)		
IP rating		IP20		
Altitude		Below 1000m		
Vibration		≤5.88m/s ² , 10~60Hz (Do not work at the resonance point)		



INVT IMS20A Series Servo Motor



Features:

- Meet comprehensive needs.
- With excellent appearance, high quality materials.
- Four-wire differential communication, easy wiring.
- Equipped with 17-bit magnetic encoder and 23-bit optical encoder, high resolution.
- Simple structure, easy to produce, obvious cost advantage.

Model description

Naming rules

IMS20A - 06 M 40B 30C - 2 - M3 4

①
②
③
④
⑤
⑥
⑦
⑧

①

Sign	Series No.
IMS20A	IMS20A series

②

Sign	Base model No.
04	40
06	60
08	80
10	100
13	130

③

Sign	Inertia classification
L	Small inertia
M	Medium inertia
H	Large inertia

④

Sign	Rated power (W)
Base (numbers) * Multiplier (letters)	
A	*1
B	*10
C	*100
...	...
40B:400W 15C:1500W	

⑤

Sign	Rated speed (rpm)
Base (numbers) * Multiplier (letters)	
A	*1
B	*10
C	*100
...	...
80B:800 rpm 30C:3000 rpm	

⑥

Sign	Voltage class (V)
2	220
4	380

⑦

Sign	Encoder type
M	Magnetic encoder
P	Optical encoder
3	17-bit single-turn
4	17-bit multiturn
9	23-bit multiturn

⑧

Sign	Optional parts
0	With oil seal but no brake (Empty by default)
4	With oil seal and electromagnetic brake

Installation dimensions

Outline dimensions of base-60 motors (unit: mm)

Motor model	L(mm)	
	Without brake	With electromagnet brake
IMS20A-06M20B30C-2-□	77	104
IMS20A-06M40B30C-2-□	96	123

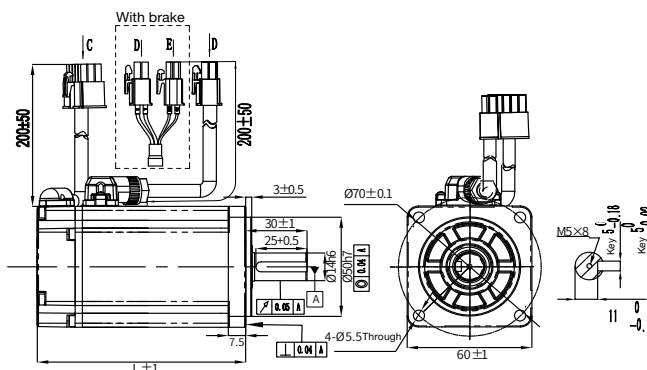

Outline dimensions of base-80 motors (unit: mm)

Motor model	L(mm)	
	Without brake	With electromagnet brake
IMS20A-08M75B30C-2-□	106	140
IMS20A-08M10C25C-2-□	120	154

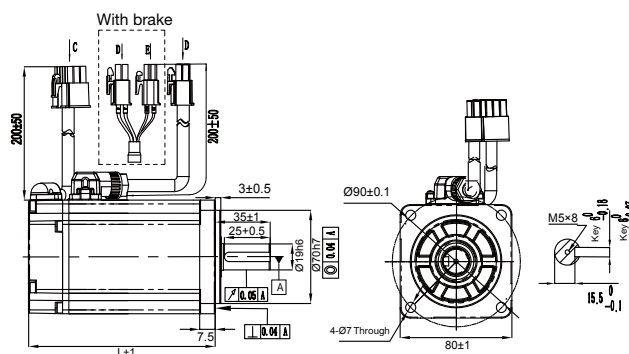

Outline dimensions of base-100 motors (unit: mm)

Motor model	L(mm)	
	Without brake	With electromagnet brake
IMS20A-10M10C30C-2(4)-□	154	194
IMS20A-10M15C30C-2(4)-□	178	218

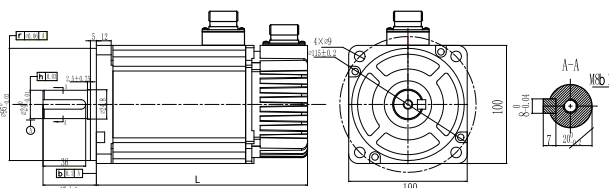

Outline dimensions of base-130 motors (unit: mm)

Motor model	L(mm)	
	Without brake	With electromagnet brake
IMS20A-13M10C20C-2(4)-□	143	185
IMS20A-13M15C20C-2(4)-□	159	201
IMS20A-13M20C20C-2-□	172	217
IMS20A-13H85B15C-2(4)-□	153	176
IMS20A-13H13C15C-2(4)-□	173	196

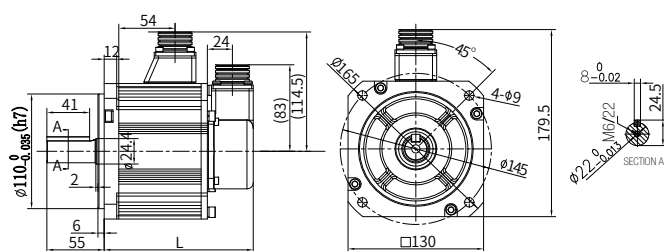

Power cable model description

Power cable

DA ML-050-03-AF0-00

① ② ③ ④ ⑤ ⑥ ⑦ ⑧

Power cable accessories

DA ML-A F

① ② ⑤ ⑥

①

Sign	Supporting series
DA	Manufacturer No.

②

Sign	Cable type
ML	Power cable

③

Sign	Cable diameter
050	0.5 mm ²
100	1.0 mm ²

④

Sign	Cable length
03	3m
05	5m
10	10m
...	Other

⑤

Sign	Motor connection plug
A	4-pin plastic plug
B	4-pin regular aviation plug YD28

⑥

Sign	Drive connection plug
F	Tube-type terminal

⑦

Sign	Cable material
0	Common cable
A	Common shielded cable
B	Shielded flexible towline cable
F	Flexible towline cable

⑧

Sign	Encoder type
00	Standard part
...	Other

Brake cable

BRKL-03-A

① ② ③

①

Sign	Product series
BRKL	Motor brake cable

②

Sign	Cable type
03	3m
...	Other

③

Sign	Motor connection plug
A	2-pin metal plug
B	3-pin regular aviation plug
D	2-pin plastic plug

Note: For brake cables, it is recommended to use the brake plug inside the motor for welding production

Power cable wiring

Power cable for base 40/60/80 motor

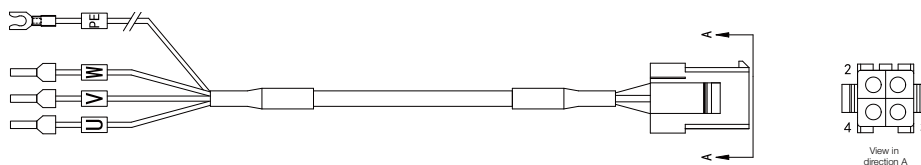

Wiring mapping			
Signal	X1	X2	Core wire color
W	Tube-type terminal	X2.3	Red
V	Tube-type terminal	X2.1	Green
U	Tube-type terminal	X2.2	Yellow
PE	Fork-type terminal	X2.4	Yellow/green

Power cable for base 100/130 motor

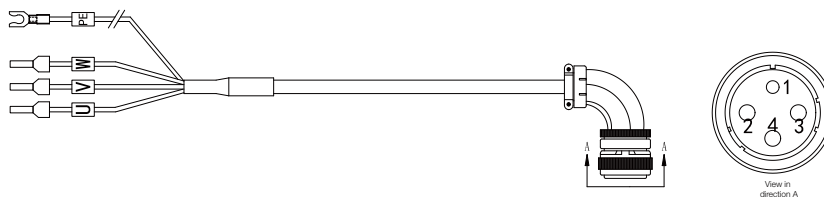

Wiring mapping			
Signal	X1	X2	Core wire color
W	Tube-type terminal	X2.4	Red
V	Tube-type terminal	X2.3	Green
U	Tube-type terminal	X2.2	Yellow
PE	Fork-type terminal	X2.1	Yellow/green

Encoder cable model description

Encoder cable

DB EL - 04 - 03 - B 0 - 04 00

① ② ③ ④ ⑤ ⑥ ⑦ ⑧

Encoder cable accessories

DB EL-A B

① ② ⑨ ⑤

①

Sign	Supporting series
DB	Manufacturer No.

②

Sign	Cable type
EL	Encoder cable

③

Sign	Number of cable cores
04	4-core
06	6-core

④

Sign	Cable length
03	3m
05	5m
10	10m
...	Other

⑤

Sign	Motor connection plug
B	15-pin regular aviation plug YD28
D	9-pin plastic plug

⑥

Sign	Cable material
0	Common cable
D	Common cable with battery box
F	Flexible towline cable
H	Flexible towline cable with battery box

⑦

Sign	Encoder type
04	Absolute

⑧

Sign	Lot No.
00	Standard part
...	Other

⑨

Sign	Drive connection plug
A	15-pin DB plug

Servo motor encoder cable wiring

Encoder cable for base 60/80 motor

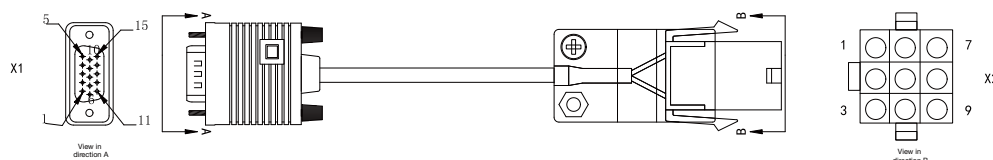

Multiturn wiring mapping			
Signal	X1	X2	Core wire structure
SD+	X1.1	X2.1	Twisted pair
SD-	X1.7	X2.2	
5V	X1.5	X2.6	Twisted pair
GND	X1.12	X2.7	
VB+	/	X2.3	Twisted pair
VB-	/	X2.8	
PE	Metal shell	X2.9	Woven

Encoder cable for base 100/130 motor



Wiring mapping			
Signal	X1	X2	Core wire structure
SD+	X1.1	X2.2	Twisted pair
SD-	X1.7	X2.3	
5V	X1.5	X2.4	Twisted pair
GND	X1.12	X2.5	
VB+	/	X2.6	Twisted pair
VB-	/	X2.7	
PE	Metal shell	X2.1	Woven

Servo motor torque-speed characteristic

Motor speed characteristic of IMS20A series motor

Note: A is a continuous working area; B is a short-time working area.

Base-40 motors

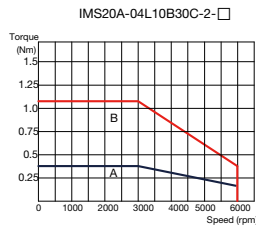

Base-60 motors

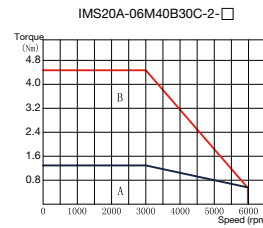
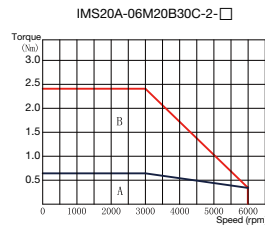

Base-80 motors

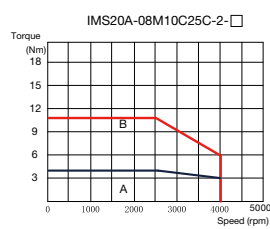
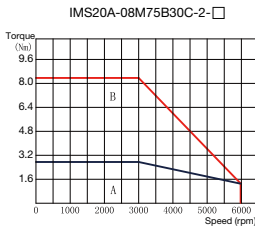

Base-100 motors

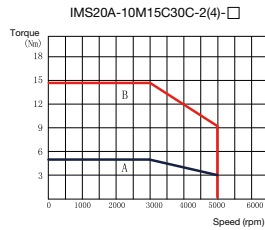
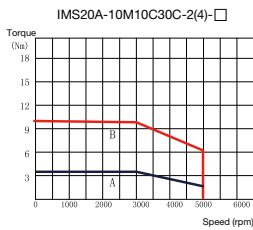

Base-130 motors

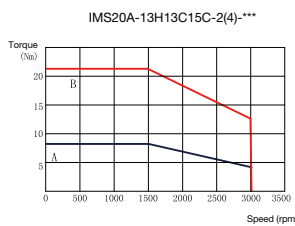
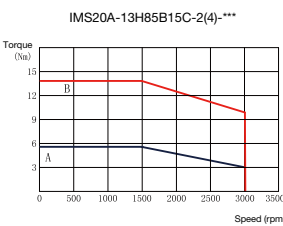
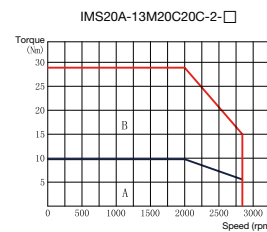
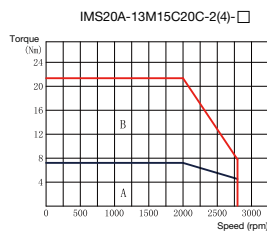
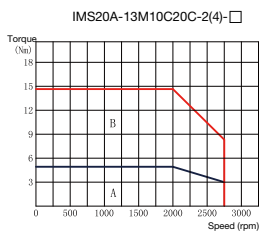

System wiring

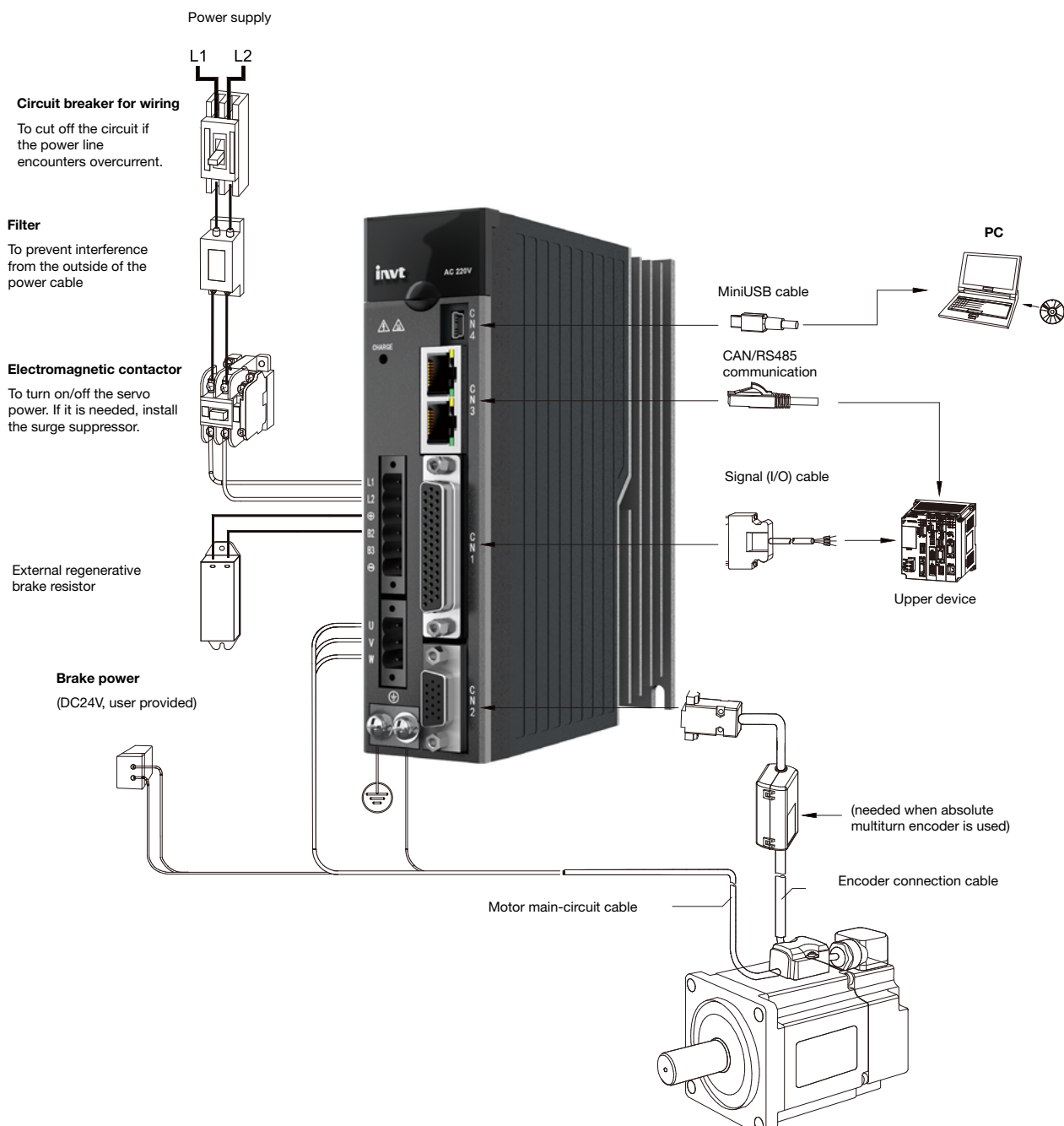

User interface

Small power range: 100W–2kW

Wiring diagram of main circuit terminal

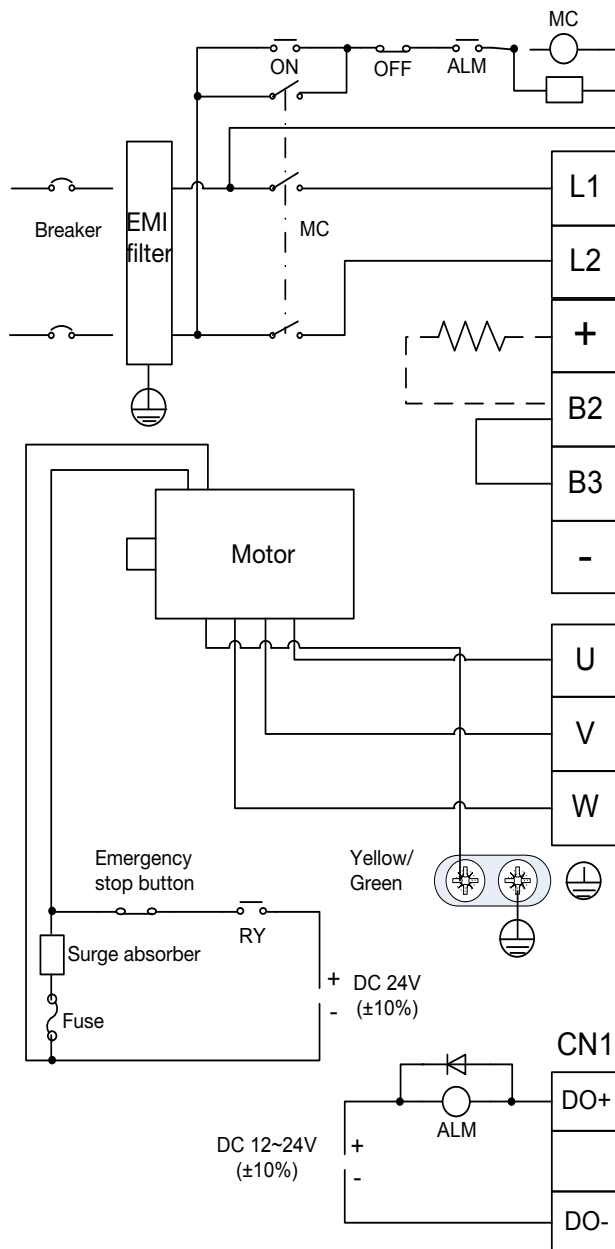

- Employ this emergency stop circuit.
- Add a surge absorber to each end of the electromagnetic contactor coil.

- Input voltage of power: AC 220V ($\pm 15\%$)

- Do not remove the jumper for connecting B2 and B3 (750W and higher) unless an external regenerative brake resistor is used.
- If you use an external regenerative brake resistor, remove the jumper between B2 and B3 and connect the resistor as shown in the dashed box.

- Connect the servo motor cables to the drive output terminals U, V, and W according to the correct phase sequence. Incorrect phase sequence may cause a drive fault.

- Ground the servo drive properly. Otherwise, electrical shocks may be caused.

- Prepare the 24VDC power for electromagnetic braking by yourself and isolate it from the DC12–24V power for signal control.
- Pay attention to free-wheeling diode connection. Reversed polarity may cause drive damage.

User interface

CN1 terminal

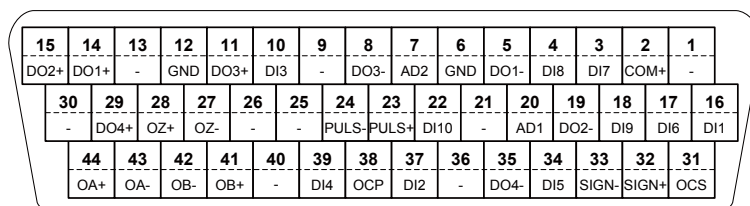

CN1 plug pins and signal codes

CN2 terminal

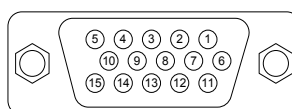

CN2 functions			
Pin	Name	Function	Remarks
1	SD+	Serial encoder data+	Only serial encoders are supported.
5	5V	Encoder power supply	
7	SD-	Serial encoder data-	
12	GND	Power ground	

CN3 terminal

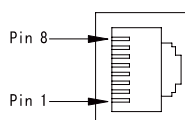

CN3 functions			
Pin	Name	Function	Remarks
1	GND_CAN	Power ground for CAN chip	See the table on the left for definition if used as 485/CAN. 485 and CAN use the same interface and each signal has two pins for multiple networking
2	GND_485	Power ground for RS485 chip	
3	/	/	
4	RS485+	RS485 data+	
5	RS485-	RS485 data-	
6	/	/	
7	CAN_L	CAN data-	
8	CAN_H	CAN data+	

Standard wiring diagram

Wiring diagram of position control
(suitable for pulse input control)

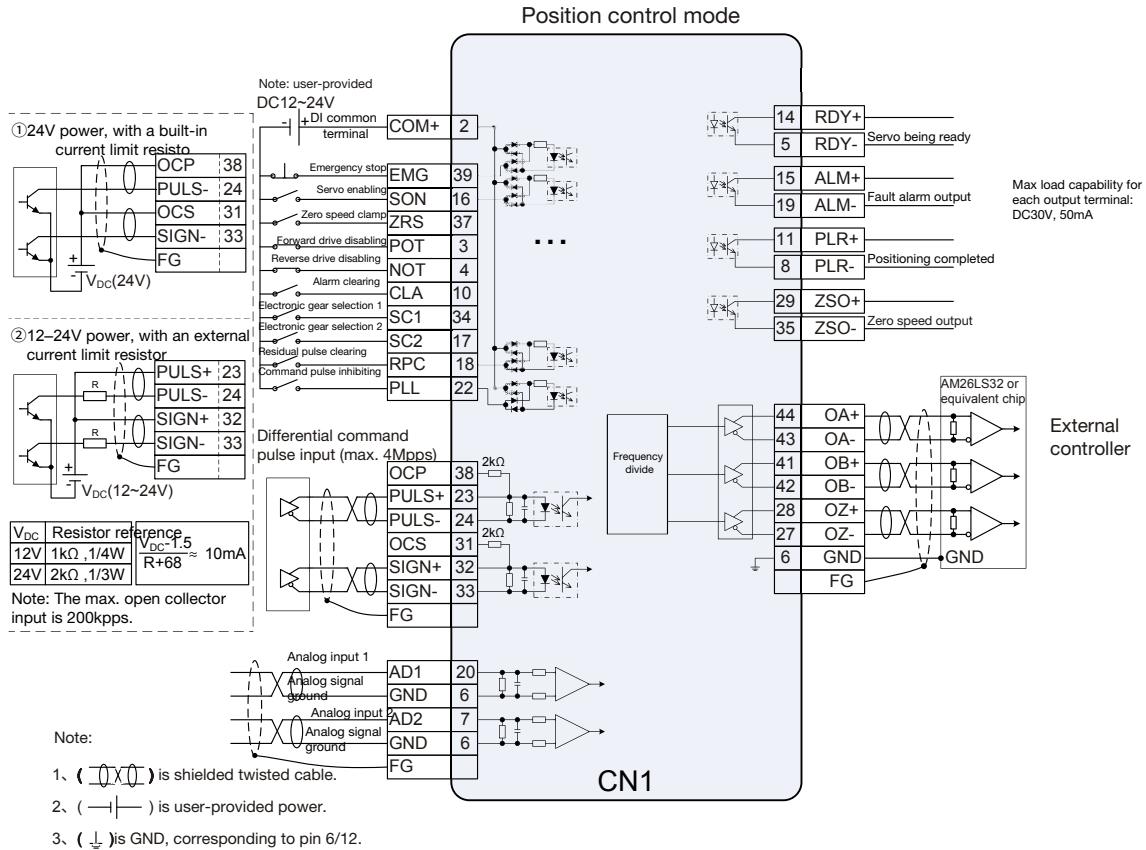

CN1 terminal

15	14	13	12	11	10	9	8	7	6	5	4	3	2	1
DO2+	DO1+	-	GND	DO3+	DI3	-	DO3-	AD2	GND	DO1-	DI8	DI7	COM+	-
30	29	28	27	26	25	24	23	22	21	20	19	18	17	16
-	DO4+	OZ+	OZ-	-	-	PULS-	PULS+	DI10	-	AD1	DO2-	DI9	DI6	DI1
44	43	42	41	40	39	38	37	36	35	34	33	32	31	
OA+	OA-	OB-	OB+	-	DI4	OC	DI2	-	DO4-	DI5	SIGN-	SIGN+	OCS	

CN1 plug pins and signal codes

Standard wiring diagram

Wiring diagram of speed mode
(suitable for analog input control)

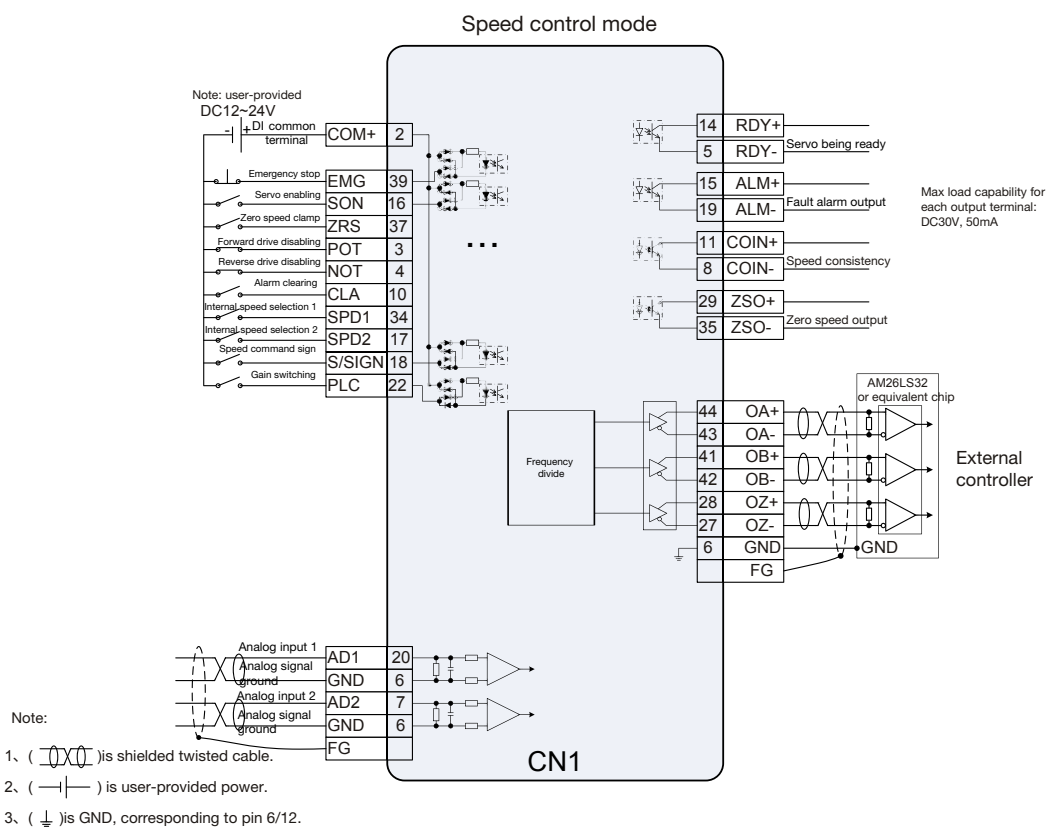

CN1 terminal

15	14	13	12	11	10	9	8	7	6	5	4	3	2	1
DO2+	DO1+	-	GND	DO3+	DI3	-	DO3-	AD2	GND	DO1-	DI8	DI7	COM+	-
30	29	28	27	26	25	24	23	22	21	20	19	18	17	16
-	DO4+	OZ+	OZ-	-	-	PULS-	PULS+	DI10	-	AD1	DO2-	DI9	DI6	DI1
44	43	42	41	40	39	38	37	36	35	34	33	32	31	
OA+	OA-	OB-	OB+	-	DI4	OCF	DI2	-	DO4-	DI5	SIGN-	SIGN+	OCS	

CN1 plug pins and signal codes

Wiring diagram of torque mode
(suitable for analog input control)

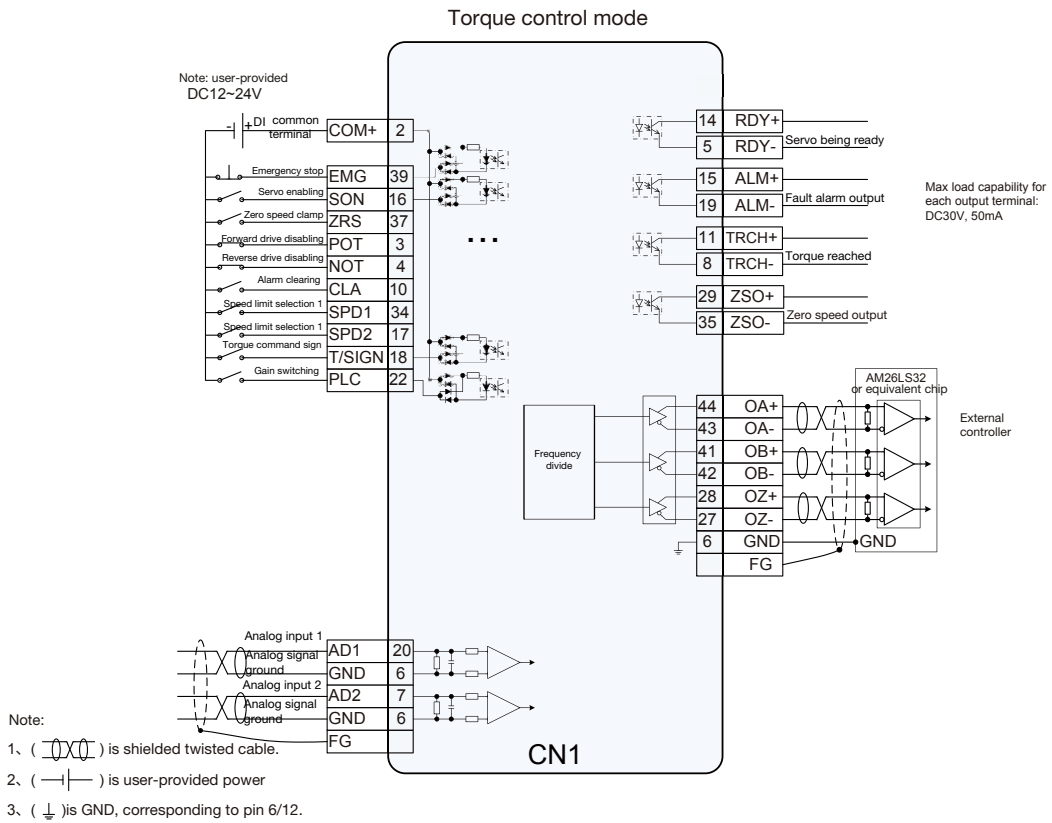

CN1 terminal

15	14	13	12	11	10	9	8	7	6	5	4	3	2	1
DO2+	DO1+	-	GND	DO3+	DI3	-	DO3-	AD2	GND	DO1-	DI8	DI7	COM+	-
30	29	28	27	26	25	24	23	22	21	20	19	18	17	16
-	DO4+	OZ+	OZ-	-	-	PULS-	PULS+	DI10	-	AD1	DO2-	DI9	DI6	DI1
44	43	42	41	40	39	38	37	36	35	34	33	32	31	
OA+	OA-	OB-	OB+	-	DI4	OCF	DI2	-	DO4-	DI5	SIGN-	SIGN+	OCS	

CN1 plug pins and signal codes

Servo system configuration table

Drive	Motor
DA180-S1R3 DA180-S1R8	IMS20A-04L10B30C-2
DA180-S1R8 DA180-S2R8	IMS20A-06M20B30C-2
DA180-S2R8	IMS20A-06M40B30C-2
DA180-S4R5	IMS20A-08M75B30C-2
DA180-S5R0	IMS20A-08M10C25C-2
DA180-S7R6	IMS20A-10M10C30C-2
DA180-T4R5	IMS20A-10M10C30C-4
DA180-S010	IMS20A-10M15C30C-2
DA180-T4R5	IMS20A-10M15C30C-4
DA180-S5R0	IMS20A-13M10C20C-2
DA180-T3R5	IMS20A-13M10C20C-4
DA180-S7R6	IMS20A-13M15C20C-2
DA180-T4R5	IMS20A-13M15C20C-4
DA180-S010	IMS20A-13M20C20C-2
DA180-S7R6	IMS20A-13H85B15C-2
DA180-T3R5	IMS20A-13H85B15C-4
DA180-S010	IMS20A-13H13C15C-2
DA180-T4R5	IMS20A-13H13C15C-4

Matching drive	Matching motor	Encoder	Cable type	Recommended cable type (without terminal)
DA180 series A, B packaging (0.2~1kW)	IMS20A-06 IMS20A-08	17-bit magnetic encoder	Power cable	DAML-050-**-AF*-**
			Encoder cable	DBEL-04-**-D* (0/F) -0400
		23-bit multiturn optical encoder	Encoder cable (with battery)	DBEL-06-**-D* (D/H) -0400
DA180 series C packaging (1~2kW)	IMS20A-10 IMS20A-13	17-bit magnetic encoder 23-bit multiturn optical encoder	Power cable	DAML-100-**-BF*-**
			Encoder cable	DBEL-06-**-B* (0/F) -0400
		23-bit multiturn optical encoder	Encoder cable (with battery)	DBEL-06-**-B* (D/H) -0400

Note: For **, refer to the cable description in page 17 20 of the manual.

Solution

INVT DA180 bus servo motion control solution

- With response frequency of 2.0 kHz, synchronous signal jitter of less than 10ns, and synchronous jitter of less than 1us.
- Surging power with 3 times overload capacity; effective vibration control.
- With automatic load inertia identifying, gain adjustment is easy to use.

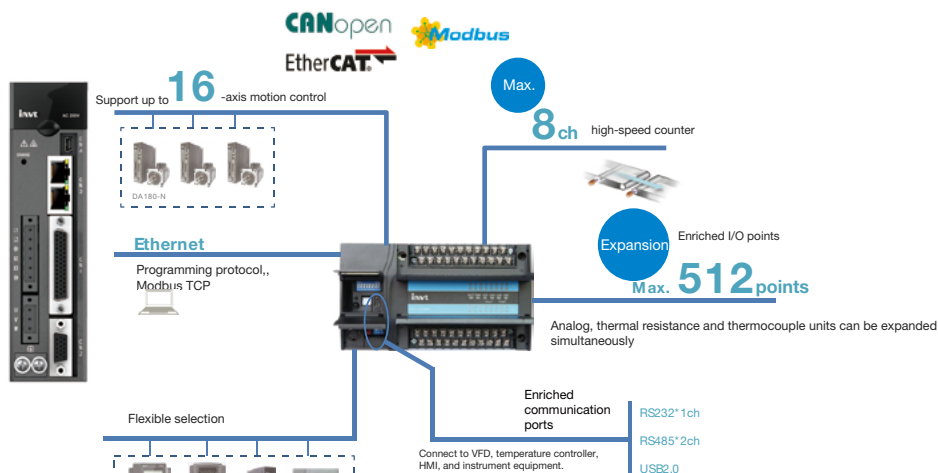

- Motion network bus EtherCAT with the fastest communication cycle of 1ms.
- Support single-axis motion commands such as position, speed, and homing.
- Support multi-axis commands such as electronic gear and electronic cam.
- The spindle can choose encoder, virtual axis or actual axis for external input

DA180 EtherCAT fieldbus solution

IVC5 small PLC can control 16 actual axes and 32 virtual axes, easily realizing multi-axis motion control.

Labeling application

IVC5 can control multi-axis servo, and can execute deceleration to stop through the external input stop signal during running. It is applicable to labelling machinery, which can execute positioning stop by the label terminal detection signal.

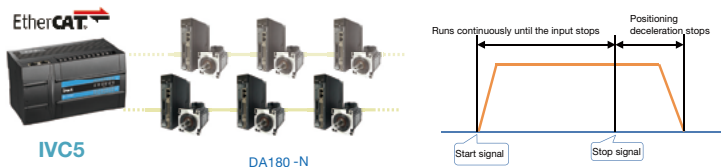

Complete solution for mask machines

- The ear mask machine adopts EtherCAT bus communication, achieving nineaxis servo control.
- Remove the wire bonding process when the network cable is connected to the servo, saving more than I/O points in the whole machine.
- More accurate cycle time control and more stable fast running.
- The control adopts the quadratic curve ACC and DEC method, with smoother curve and less mechanical impact.
- The production efficiency can up to 120 pieces per minute during steady production.



/ INVT industrial automation product family



■ HMI

- VA series
- VK series
- VS series
- TC series
- VT series



■ Controller

- IVC1S series delicate programmable controller
- IVC1L series flexible programmable controller
- IVC2 series general programmable controller
- IVC3 series high-performance programmable controller
- AX series high-performance generic programmable controller



■ Servo system

- General servo drive system
- Industry-specific servo system
- Industry-specific electronic control system



■ VFD

- Low voltage general VFD
- Medium voltage VFD
- High voltage VFD
- Industry-specific drive



www.realtechotomasyon.com.tr

Your trusted industry automation solution provider



E-mail: overseas@invt.com.cn Website: www.invt.com

SHENZHEN INVT ELECTRIC CO.,LTD. INVT Guangming Technology Building, Songbai Road, Matian, Guangming District, Shenzhen, China

- | | | | | |
|-------------------------------|----------------------------------------------|---------------------------------------|----------------------------|-----------------------------------|
| Industrial Automation: | • Frequency AC Drive | • Servo & Motion Control | • Motor & Electric Spindle | • PLC |
| | • HMI | • Intelligent Elevator Control System | • Traction Drive | |
| Electric Power: | • SVG | • Solar Pump Controller | • UPS | • Online Energy Management System |
| | • New Energy Vehicle Electric Control System | | | |

INVT Copyright.
Information may be subject to change without notice during product improving.

66003-00298 202305(V2.3)