



Realtech

www.realtechotomasyon.com.tr



İstanbul

Oruçreis Mah. Giyimkent 5. Sk.
Giyimkent B57 NO: 82/A
Esenler İstanbul / Türkiye

0 (212) 438 11 80
0 (533) 374 45 92

info@realtechotomasyon.com.tr

Gaziantep

Mücahitler Mah. 52008 Nolu Cad. No:3/J
Şehitkamil Gaziantep / Türkiye

0 (342) 503 11 83
0 (544) 948 40 40

ibrahim@realtechotomasyon.com.tr

Panasonic

PROGRAMMABLE CONTROLLERS

FP7 Digital I/O Units

User's Manual

Before beginning

Liability and copyright for the hardware

This manual and everything described in it are copyrighted. You may not copy this manual, in whole or part, without written consent of Panasonic Electric Works Europe AG (PEWEU).

PEWEU pursues a policy of continuous improvement of the design and performance of its products. Therefore we reserve the right to change the manual/product without notice. In no event will PEWEU be liable for direct, special, incidental, or consequential damage resulting from any defect in the product or its documentation, even if advised of the possibility of such damages.

We invite your comments on this manual. Please e-mail us at:

techdoc.peweu@eu.panasonic.com.

Please direct support matters and technical questions to your local Panasonic representative.

Limited warranty

If physical defects caused by distribution are found, PEWEU will replace/repair the product free of charge. Exceptions include:

- When physical defects are due to different usage/treatment of the product other than described in the manual.
- When physical defects are due to defective equipment other than the distributed product.
- When physical defects are due to modifications/repairs by someone other than PEWEU.
- When physical defects are due to natural disasters.

Warnings used in this manual

One or more of the following warnings may be used in this documentation:

DANGER	
	Indicates a hazardous situation which, if not avoided, will result in death or serious injury.

WARNING	
	Indicates a hazardous situation which, if not avoided, could result in serious or moderate injury.

CAUTION	
	Indicates a hazardous situation which, if not avoided, could result in minor or moderate injury.

NOTICE	
	Indicates a property damage message.

Scope of this manual

This manual covers:

- unit types
- parts and functions
- input and output specifications
- input time constant setting function
- wiring instructions

Please refer to the FP7 CPU Hardware User's Manual for information on:

- restrictions on unit combinations
- I/O allocation methods
- operating instructions
- troubleshooting information
- maintenance instructions
- error codes
- unit dimensions

Please refer to the FP Series Programming Manual or to the online help of Control FPWIN Pro for information on:

- system instructions
- special internal relays
- data registers
- system variables
- memory area tables
- programming examples

For documentation on other units used with the FP7, please refer to the hardware manual for that unit.

All manuals can be downloaded from the Panasonic Web site (<http://www.panasonic-electric-works.com>).

Safety measures

Operating environment

After installing the unit, make sure to use it within the range of the general specifications:

- Ambient temperature: 0°C to +55°C
- Ambient humidity: 10%–95% RH (at 25°C, non-condensing)
- Pollution degree: 2
- Do not use the unit in the following environments:
 - Direct sunlight
 - Sudden temperature changes causing condensation
 - Inflammable or corrosive gases
 - Excessive airborne dust, metal particles or salts
 - Benzine, paint thinner, alcohol or other organic solvents or strong alkaline solutions such as ammonia or caustic soda
 - Vibration, shock or direct drop of water
 - Influence from power transmission lines, high voltage equipment, power cables, power equipment, radio transmitters, or any other equipment that would generate high switching surges. Maintain at least 100mm of space between these devices and the unit.

Static electricity

Before touching the unit or equipment, always touch some grounded metal to discharge any static electricity you may have generated (especially in dry locations). The discharge of static electricity can damage parts and equipment.

Protection of power supply

- Use a twisted power supply wire.
- Isolate the wiring systems to the CPU, input/output devices, and mechanical power apparatus.
- An insulated power supply with an internal protective circuit should be used (FP power supply). The power supply for the CPU is a non-insulated circuit, so if an incorrect voltage is directly applied, the internal circuit may be damaged or destroyed.

- If using a power supply device without an internal protective circuit, always make sure power is supplied to the unit through a protective element such as a fuse.
- Be sure to supply power to a CPU and an expansion unit from the same power supply, and turn the power on and off simultaneously for both.

Power supply sequence

Make sure the power supply of the CPU turns off before the power supply for input and output. If the power supply for input and output is turned off first, the CPU will detect the input fluctuations and may begin an unexpected operation.

Before turning on the power

When turning on the power for the first time, be sure to take the precautions given below.

- During installation, check that there are no scraps of wiring, particularly conductive fragments, adhering to the unit.
- Verify that the power supply wiring, I/O wiring, and power supply voltage are all correct.
- Sufficiently tighten the installation and terminal screws.
- Set the operation mode selector to PROG mode.

Request concerning program storage

To prevent the accidental loss of programs, the user should consider the following measures:

- Backing up programs: To avoid accidentally losing programs, destroying files, or overwriting the contents of a file, use the backup or export functions of Control FPWIN Pro and store the files in a safe place. Additionally, you can print out the entire project documentation.
- Specifying passwords: The password setting is designed to avoid programs being accidentally overwritten. If the password is forgotten, however, it will be impossible to overwrite the program even if you want to. Also, if a password is forcibly bypassed, the program is deleted. Therefore, please note the password in a safe location.

Table of contents

1. Overview	9
1.1 Unit types	9
1.2 Parts and functions	10
2. Specifications	12
2.1 General specifications	12
2.2 Current consumption	13
2.3 Input unit specifications	13
2.3.1 16 inputs (AFP7X16DW)	13
2.3.2 32 inputs (AFP7X32D2)	14
2.3.3 64 inputs (AFP7X64D2)	16
2.4 Output unit specifications	18
2.4.1 16 relay outputs (AFP7Y16R)	18
2.4.2 16 sink (NPN) outputs (AFP7Y16T)	20
2.4.3 16 source (PNP) outputs (AFP7Y16P)	21
2.4.4 32 sink (NPN) outputs (AFP7Y32T)	23
2.4.5 32 source (PNP) outputs (AFP7Y32P)	25
2.4.6 64 sink (NPN) outputs (AFP7Y64T)	27
2.4.7 64 source (PNP) outputs (AFP7Y64P)	29
2.5 Mixed I/O unit specifications	33
2.5.1 32 inputs/32 sink (NPN) outputs (AFP7XY64D2T)	33
2.5.2 32 inputs/32 source (PNP) outputs (AFP7XY64D2P)	38
2.6 Input time constant setting function	43
3. Wiring	44
3.1 Before wiring	44
3.2 Input wiring	44
3.2.1 Photoelectric and proximity sensors	44
3.2.2 Input wiring precautions	47
3.3 Output wiring	50
3.3.1 Protective circuit for inductive loads	50
3.3.2 Protective circuit for capacitive loads	51
3.3.3 Overload protection	51
3.3.4 Grounding of AFP7Y16R	52
3.4 Wiring the terminal block	53
3.5 Wiring the MIL connector	54
3.5.1 Connectors for wire-pressed terminal cables	54

3.5.2 Flat cable connectors 57

Chapter 1

Overview

1.1 Unit types

Input unit

Type	Inputs	Connection	Description	Product no.
DC input	16	Terminal block	12–24V DC ±COM terminal Response time configurable	AFP7X16DW
	32	MIL connector	24V DC ±COM terminal Response time configurable	AFP7X32D2
	64	MIL connector	24V DC ±COM terminal Response time configurable	AFP7X64D2

Output unit

Type	Outputs	Connection	Description	Product no.
Relay	16	Terminal block	Load current: 2A/output, 5A/common; 16 outputs/common; without relay socket	AFP7Y16R
Transistor, sink (NPN)	16	Terminal block	Load current: 1A/output, 5A/common; 16 outputs/common	AFP7Y16T
	32	MIL connector	Load current: 0.3A/output, 3.2A/common; 32 outputs/common	AFP7Y32T
	64	MIL connector	Load current: 0.3A (8 outputs, Y0–Y7) and 0.1A (56 outputs, Y8–Y3F), 3.2A/common; 32 outputs/common	AFP7Y64T
Transistor, source (PNP)	16	Terminal block	Load current: 1A/output, 5A/common; 16 outputs/common	AFP7Y16P
	32	MIL connector	Load current: 0.3A/output, 3.2A/common; 32 outputs/common	AFP7Y32P
	64	MIL connector	Load current: 0.3A (8 outputs, Y0–Y7) and 0.1A (56 outputs, Y8–Y3F); 3.2A/common; 32 outputs/common	AFP7Y64P

Mixed I/O unit

Type	I/Os	Connection	Description	Product no.
DC input Transistor output, sink (NPN)	Inputs: 32	MIL connector	24V DC ±COM terminal Response time configurable	AFP7XY64D2T
	Outputs: 32	MIL connector	Load current: 0.3A (8 outputs, Y0–Y7) and 0.1A (24 outputs: Y8–Y1F); 3.2A/common; 32 outputs/common	
DC input Transistor output, source (PNP)	Inputs: 32	MIL connector	24V DC ±COM terminal Response time configurable	AFP7XY64D2P
	Outputs: 32	MIL connector	Load current 0.3A (8 outputs: Y0–Y7) and 0.1A (24 outputs: Y8–Y1F); 3.2A/common and 32 outputs/common	

1.2 Parts and functions

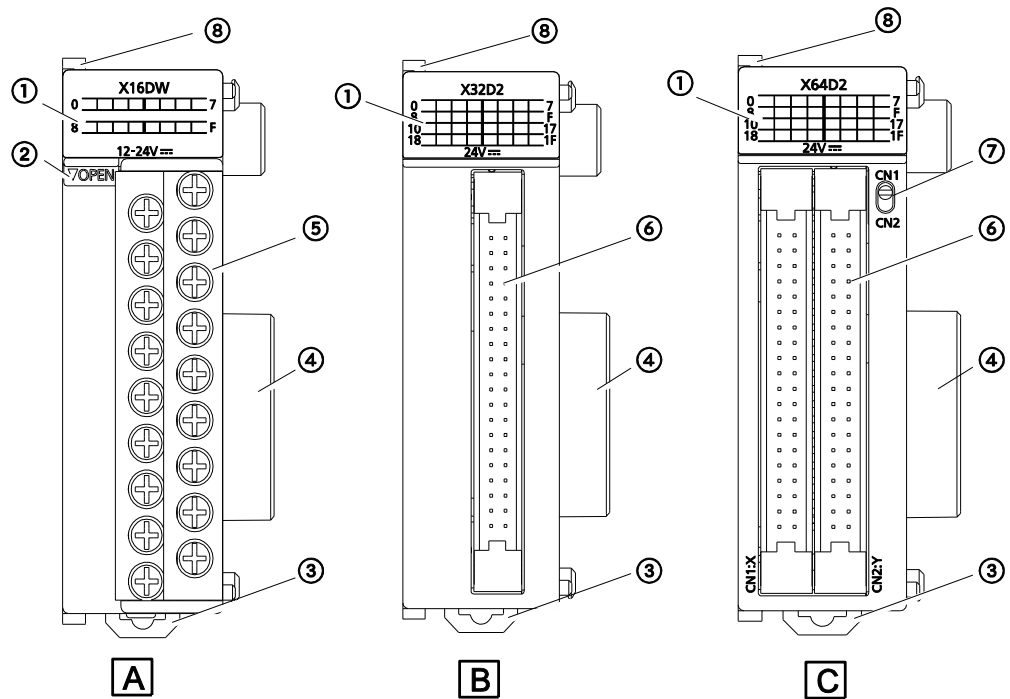

- A** Terminal block type, 16 inputs
- B** MIL connector type, 32 inputs
- C** MIL connector type, 64 inputs

① Input status LEDs/Output status LEDs

Indicate the ON/OFF status of each input and output.

② Terminal block release lever

By lowering this lever, the terminal block can be removed from the unit without disconnecting the wiring. After installation, push in the lock button at the bottom of the unit to lock in the terminal block.

③ DIN rail attachment lever

Used for easy attachment to a DIN rail.

④ Expansion connector

Used to connect the internal circuits of two or more units.

⑤ Terminal block

Connect power supplies for the purpose of operating and driving I/O circuits.

⑥ 40-pin MIL connector

Connect power supplies for the purpose of operating and driving I/O circuits. Connectors for wire-pressed terminal cables or flat cable connectors can be used.

⑦ Input/output LED selector

Switches between the first 32 LEDs and the second 32 LEDs of the display for units with 64 I/Os.

⑧ Expansion hook

Used to fix expansion units.

Chapter 2

Specifications

2.1 General specifications

Item	Description		
Ambient temperature	0 to +55°C		
Storage temperature	-40 to +70°C		
Ambient humidity	10%–95% RH (at 25°C, non-condensing)		
Storage humidity	10%–95% RH (at 25°C, non-condensing)		
Breakdown voltage (Cutoff current: 5mA)		DC input Transistor output	Relay output
	Input terminals ↔ Output terminals	500V AC for 1min	–
	Output terminals ↔ Output terminals (of different COM terminals)	500V AC for 1min	2300V AC for 1min
	Input terminals ↔ Power supply terminal/Function earth	500V AC for 1min	–
	Output terminals ↔ Power supply terminal/Function earth	500V AC for 1min	2300V AC for 1min
Insulation resistance (measured with a 500V DC megger)	Input terminals ↔ Output terminals	Min. 100Ω	–
	Output terminals ↔ Output terminals (of different COM terminals)	Min. 100Ω	Min. 100Ω
	Input terminals ↔ Power supply terminal/Function earth	Min. 100Ω	–
	Output terminals ↔ Power supply terminal/Function earth	Min. 100Ω	Min. 100Ω
Vibration resistance ¹⁾	5–8.4Hz, amplitude of 3.5mm 8.4–150Hz, constant acceleration of 9.8m/s ² , 10min on 3 axes (1 octave/min)		
Shock resistance ¹⁾	≥147m/s ² , 3 times on 3 axes (in X, Y, and Z direction)		
Noise immunity	DC input/Transistor output: 1000Vp-p with pulse widths 50ns and 1μs (based on in-house measurements) Relay output: 1000Vp-p with pulse widths 50ns and 1μs (based on in-house measurements)		
Operation conditions	Free from corrosive gases and excessive dust		
Conformity to CE Directives	EMC: EN 61131-2, LVD: EN 61131-2		
Overvoltage category	II		
Pollution degree	2		

¹⁾ Based on JIS B 3502 and IEC 61131-2

2.2 Current consumption

Type of unit	I/Os	Internal current consumption (24V DC)	Product no.
DC input	16	≤25mA	AFP7X16DW
	32	≤30mA	AFP7X32D2
	64	≤35mA	AFP7X64D2
Relay output	16	≤180mA	AFP7Y16R
Transistor output, sink (NPN)	16	≤35mA	AFP7Y16T
	32	≤50mA	AFP7Y32T
	64	≤75mA	AFP7Y64T
Transistor output, source (PNP)	16	≤35mA	AFP7Y16P
	32	≤50mA	AFP7Y32P
	64	≤75mA	AFP7Y64P
Mixed I/O unit DC input/Transistor output, sink (NPN)	Input: 32 Output: 32	≤55mA	AFP7XY64D2T
Mixed I/O unit DC input/Transistor output, source (PNP)	Input: 32 Output: 32	≤55mA	AFP7XY64D2P

2.3 Input unit specifications

2.3.1 16 inputs (AFP7X16DW)

Item	Description	
Insulation method	Optical coupler	
Rated input voltage	12–24V DC	
Rated input current	≈6mA (at 24V DC)	
Input impedance	≈3.6kΩ	
Operating voltage range	10.2–26.4V DC	
Min. ON voltage/min. ON current	9.6V DC/2mA	
Max. OFF voltage/max. OFF current	2.5V DC/1mA	
Response time	FALSE → TRUE	≤0.1ms (input time constant configurable)
	TRUE → FALSE	≤0.2ms (input time constant configurable)
Input points per common	8	
Input status LEDs	16 (lit in ON state)	
Connection	Terminal block (Terminal screw M3)	
Weight	≈125g	

Internal circuit diagram

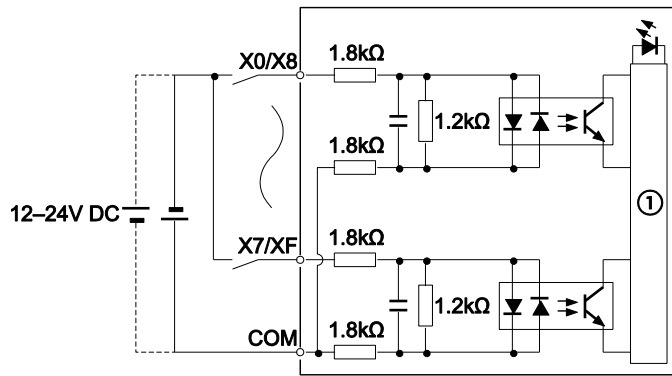

① Internal circuit

Terminal layout

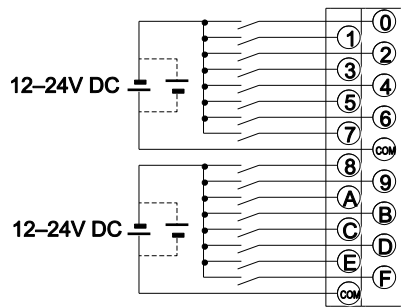

2.3.2 32 inputs (AFP7X32D2)

Item		Description
Insulation method		Optical coupler
Rated input voltage		24V DC
Rated input current		≈2.7mA (at 24V DC)
Input impedance		≈8.2kΩ
Operating voltage range		20.4–26.4V DC
Min. ON voltage/min. ON current		19.2V DC/2.5mA
Max. OFF voltage/max. OFF current		5V DC/1.5mA
Response time	FALSE → TRUE	≤0.2ms (input time constant configurable)
	TRUE → FALSE	≤0.2ms (input time constant configurable)
Input points per common		32
Input status LEDs		32 (lit in ON state)
Connection		40-pin MIL connector
Weight		≈95g

Internal circuit diagram

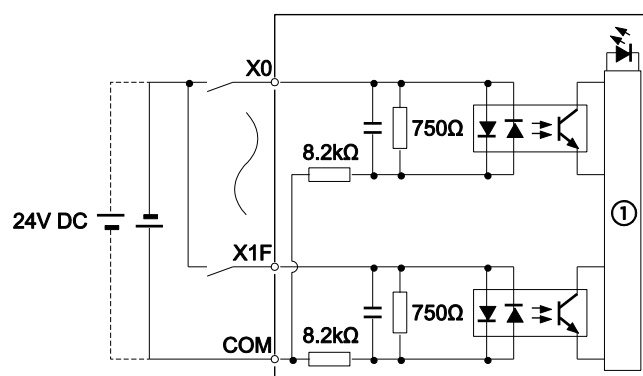

① Internal circuit

Terminal layout

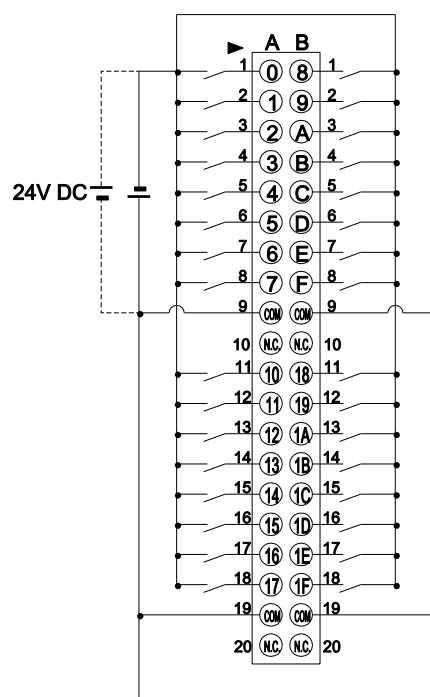

The COM terminals of the input circuits are connected internally.

2.3.3 64 inputs (AFP7X64D2)

Item		Description
Insulation method		Optical coupler
Rated input voltage		24V DC
Rated input current		≈2.7mA (at 24V DC)
Input impedance		≈8.2kΩ
Operating voltage range		20.4–26.4V DC
Min. ON voltage/min. ON current		19.2V DC/2.5mA
Max. OFF voltage/max. OFF current		5V DC/1.5mA
Response time	FALSE → TRUE	≤0.2ms (input time constant configurable)
	TRUE → FALSE	≤0.2ms (input time constant configurable)
Input points per common		32
Input status LEDs		32 (lit in ON state)
Connection		40-pin MIL connector
Weight		≈110g

Inputs that are TRUE simultaneously

Keep the number of inputs per common which are simultaneously TRUE within the following range as determined by the ambient temperature.

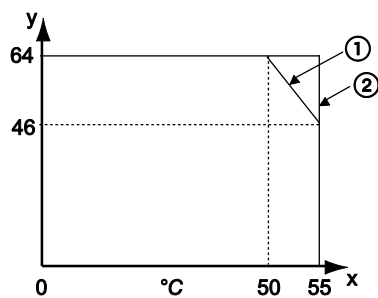

x	Ambient temperature
y	Number of inputs per common that are TRUE simultaneously
①	At 26.4V DC
②	At 24V DC

Internal circuit diagram

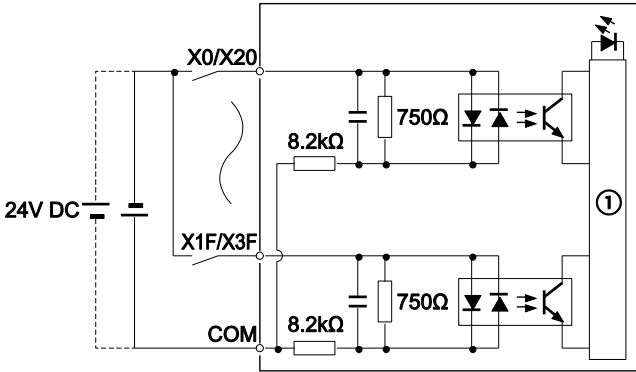

① Internal circuit

Terminal layout

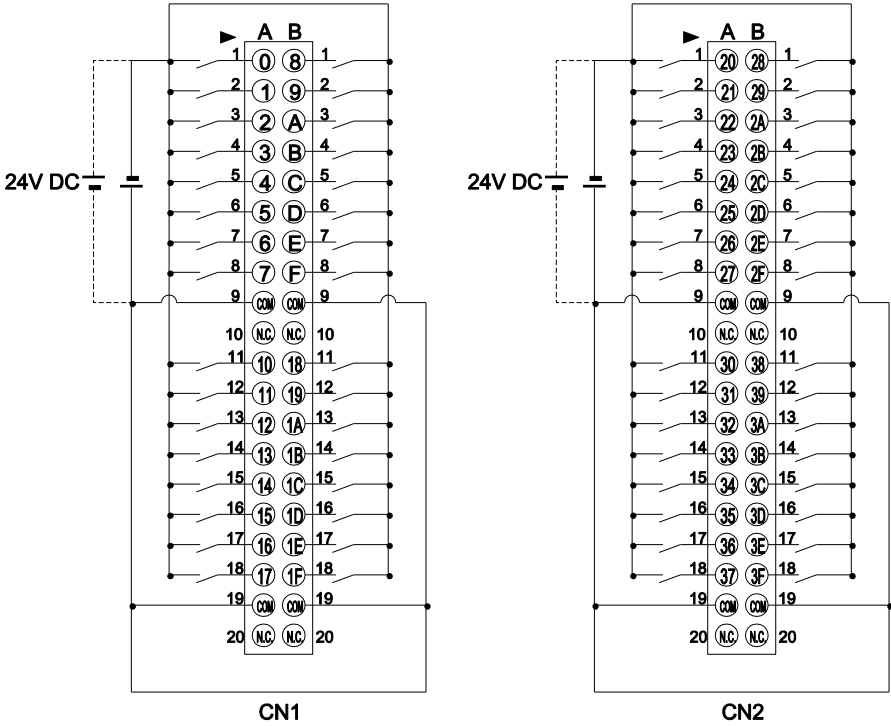

The COM terminals of each connector are connected internally.

2.4 Output unit specifications

2.4.1 16 relay outputs (AFP7Y16R)

Item	Description	
Insulation method	Relay	
Nominal switching capacity (resistive load)	2A 250V AC, 2A 30V DC (5A/common)	
Minimum load current	1mA 100mV (resistive load)	
Response time	FALSE → TRUE	≈10ms
	TRUE → FALSE	≈8ms
Mechanical lifetime	≥20 000 000 operations (switching frequency: 180 operations/min)	
Electrical lifetime	≥100 000 operations (switching frequency at nominal switching capacity: 20 operations/min)	
Surge absorber	Snubber circuit (Leakage current: ≤0.2mA)	
Relay sockets	–	
Outputs per common	16	
Operation indicator	16-point LED indicator (lit in ON state)	
Connection	Terminal block (M3 terminal screws)	
Weight	≈180g	

Internal circuit diagram

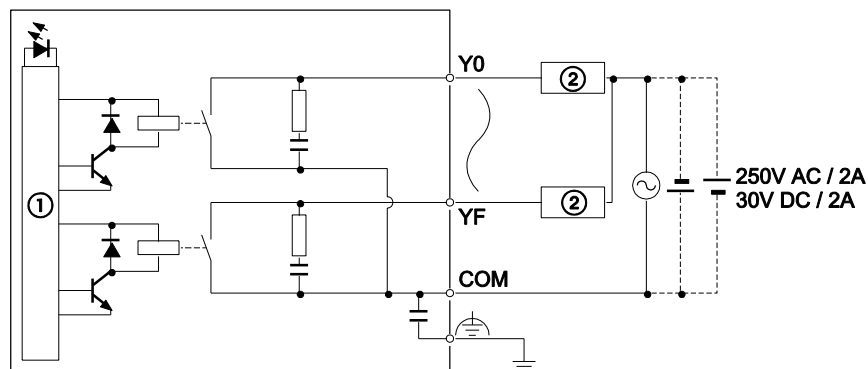

- ① Internal circuit
- ② Load

In order to avoid the effects of noise, be sure to ground the function earth terminal.

Restriction on power supply voltage

Refer to the following figure and reduce the supply voltage according to the ambient temperature.

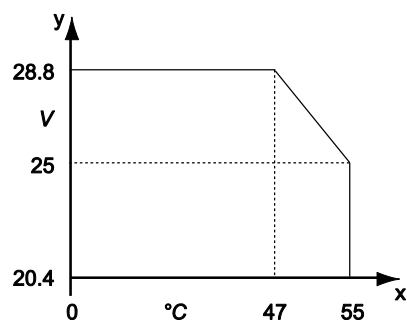

x Ambient temperature
y Power supply voltage

Terminal layout

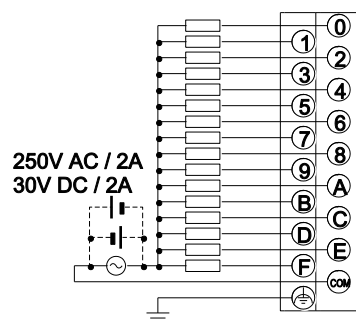

2.4.2 16 sink (NPN) outputs (AFP7Y16T)

Item		Description
Insulation method		Optical coupler
Output type		Open collector
Rated load voltage		5–24V DC
Operating load voltage range		4.75–26.4V DC
Max. load current		1A/output (max. 5A/common)
Max. inrush current		3A
OFF state leakage current		≤1μA
ON state voltage drop		≤0.5V
Response time	FALSE → TRUE	≤0.05ms (load current: ≥0.5mA)
	TRUE → FALSE	≤0.3ms (load current: ≥0.5mA)
External power supply	Voltage	4.75–26.4V DC
	Current	70mA (at 24V DC)
Surge absorber		Zener diode
Short circuit protection		–
Outputs per common		16
Operation indicator		16-point LED indicator (lit in ON state)
Connection		Terminal block (M3 terminal screws)
Weight		≈125g

Internal circuit diagram

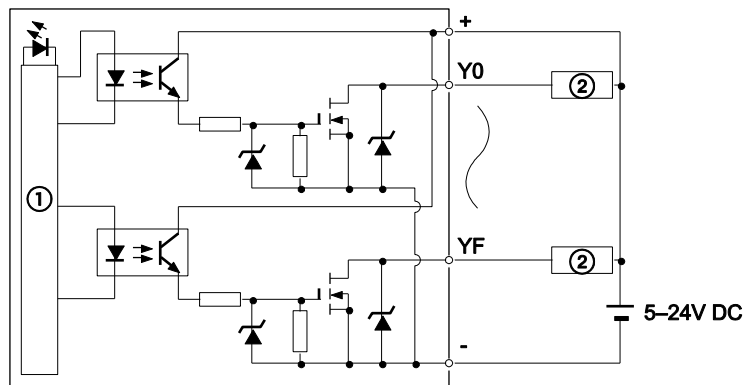

- ① Internal circuit
- ② Load

Terminal layout

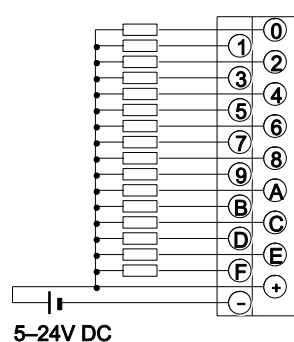

2.4.3 16 source (PNP) outputs (AFP7Y16P)

Item	Description	
Insulation method	Optical coupler	
Output type	Open collector	
Rated load voltage	5–24V DC	
Operating load voltage range	4.75–26.4V DC	
Max. load current	1A/output (max. 5A/common)	
Max. inrush current	3A	
OFF state leakage current	≤1μA	
ON state voltage drop	≤0.5V	
Response time	FALSE → TRUE	≤0.05ms (load current: ≥0.5mA)
	TRUE → FALSE	≤0.3ms (load current: ≥0.5mA)
External power supply	Voltage	4.75–26.4V DC
	Current	70mA (at 24V DC)
Surge absorber	Zener diode	
Short circuit protection	-	
Outputs per common	16	
Operation indicator	16-point LED indicator (lit in ON state)	
Connection	Terminal block (M3 terminal screws)	
Weight	≈125g	

Internal circuit diagram

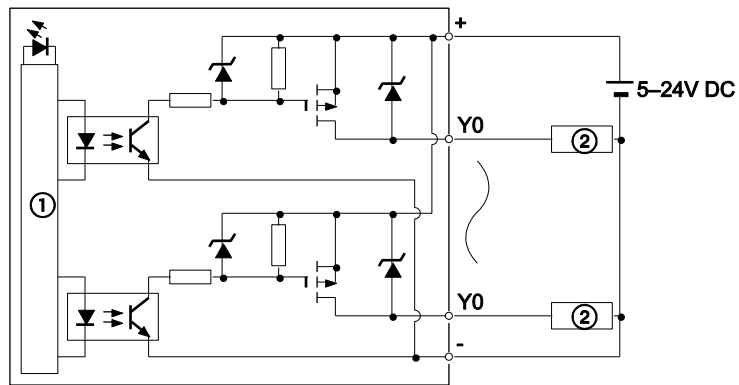

- ① Internal circuit
- ② Load

Terminal layout

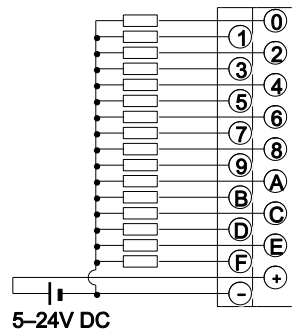

2.4.4 32 sink (NPN) outputs (AFP7Y32T)

Item	Description	
Insulation method	Optical coupler	
Output type	Open collector	
Rated load voltage	5–24V DC	
Operating load voltage range	4.75–26.4V DC	
Max. load current	0.3A/output (20.4–26.4V DC) and 30mA/output (4.75V DC) (max. 3.2A/common)	
Max. inrush current	0.6A	
OFF state leakage current	≤1μA	
ON state voltage drop	≤0.5V	
Response time	FALSE → TRUE	≤0.1ms (load current: ≥1mA)
	TRUE → FALSE	≤0.3ms (load current: ≥1mA)
External power supply	Voltage	4.75–26.4V DC
	Current	110mA (at 24V DC)
Surge absorber	Zener diode	
Short circuit protection	–	
Outputs per common	32	
Operation indicator	32-point LED indicator (lit in ON state)	
Connection	40-pin MIL connector	
Weight	≈95g	

Internal circuit diagram

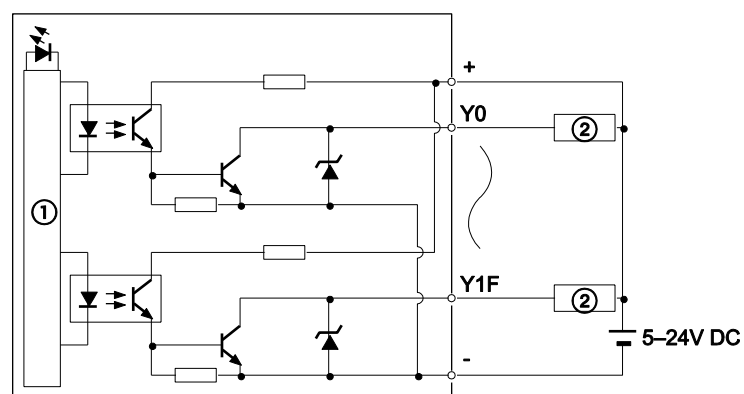

- ① Internal circuit
- ② Load

Restrictions on load current

Refer to the following figure and reduce the load current according to the external power supply voltage.

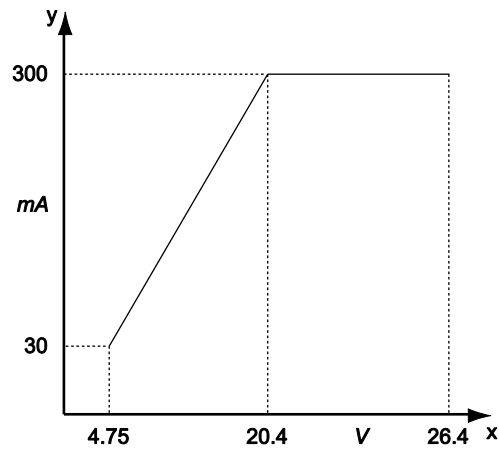

- x External power supply voltage
- y Max. load current

Terminal layout

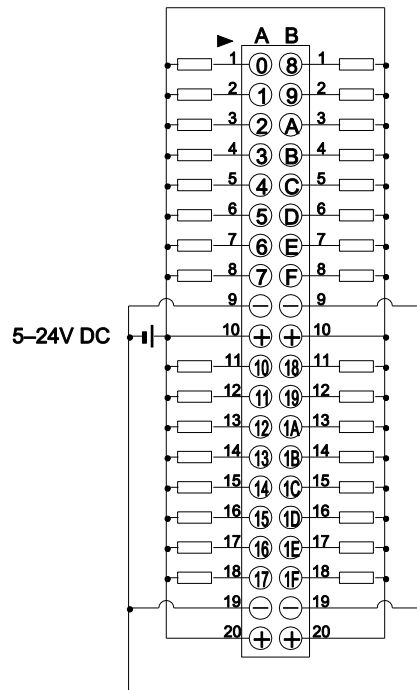

Although the positive and negative terminals are connected internally, connect these terminals externally as well.

2.4.5 32 source (PNP) outputs (AFP7Y32P)

Item	Description	
Insulation method	Optical coupler	
Output type	Open collector	
Rated load voltage	5–24V DC	
Operating load voltage range	4.75–26.4V DC	
Max. load current	0.3A/output (20.4–26.4V DC) and 30mA/output (4.75V DC) (max. 3.2A/common)	
Max. inrush current	0.6A	
OFF state leakage current	$\leq 1\mu\text{A}$	
ON state voltage drop	$\leq 0.5\text{V}$	
Response time	FALSE \rightarrow TRUE	$\leq 0.1\text{ms}$ (load current: $\geq 2\text{mA}$)
	TRUE \rightarrow FALSE	$\leq 0.5\text{ms}$ (load current: $\geq 2\text{mA}$)
External power supply	Voltage	4.75–26.4V DC
	Current	130mA (at 24V DC)
Surge absorber	Zener diode	
Short circuit protection	–	
Outputs per common	32	
Operation indicator	32-point LED indicator (lit in ON state)	
Connection	40-pin MIL connector	
Weight	$\approx 95\text{g}$	

Internal circuit diagram

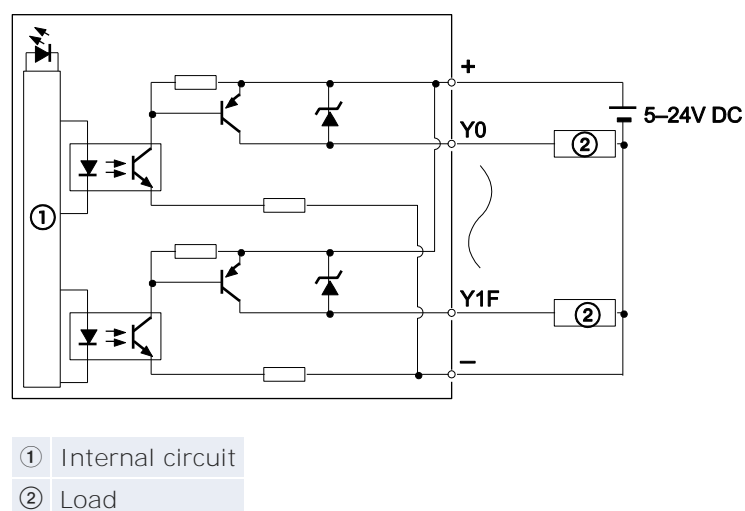

Restrictions on load current

Refer to the following figure and reduce the load current according to the external power supply voltage.

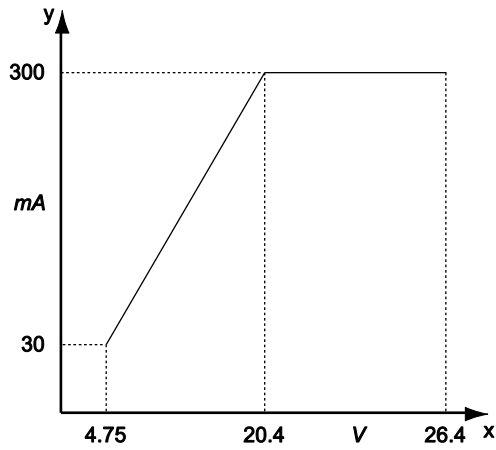

x	External power supply voltage
y	Max. load current

Terminal layout

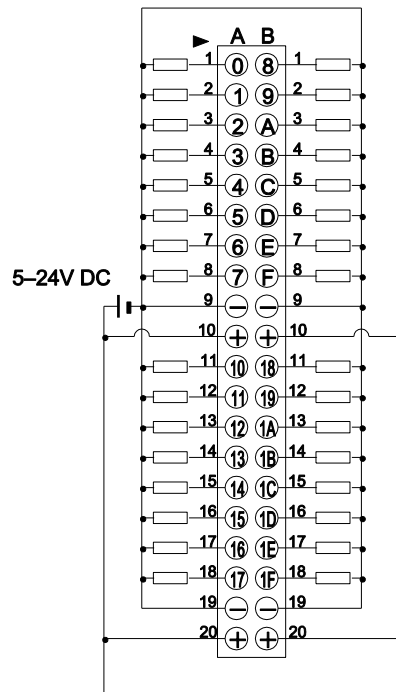

Although the positive and negative terminals are connected internally, connect these terminals externally as well.

2.4.6 64 sink (NPN) outputs (AFP7Y64T)

Item		Description
Insulation method		Optical coupler
Output type		Open collector
Rated load voltage		5–24V DC
Operating load voltage range		4.75–26.4V DC
Max. load current	Y0–Y7	0.3A/output (20.4–26.4V DC) and 30mA/output (4.75V DC) (max. 3.2A/common)
	Any other output	0.1A/output (20.4–26.4V DC) and 15mA/output (4.75V DC) (max. 3.2A/common)
Max. inrush current		0.6A
OFF state leakage current		$\leq 1\mu\text{A}$
ON state voltage drop		$\leq 0.5\text{V}$
Response time	FALSE → TRUE	$\leq 0.1\text{ms}$ (load current: $\geq 2\text{mA}$)
	TRUE → FALSE	$\leq 0.3\text{ms}$ (load current: $\geq 2\text{mA}$)
External power supply	Voltage	4.75–26.4V DC
	Current	70mA/common (at 24V DC)
Surge absorber		Zener diode
Short circuit protection		–
Outputs per common		32
Operation indicator		32-point LED indicator (lit in ON state)
Connection		40-pin MIL connector x2
Weight		$\approx 115\text{g}$

Internal circuit diagram

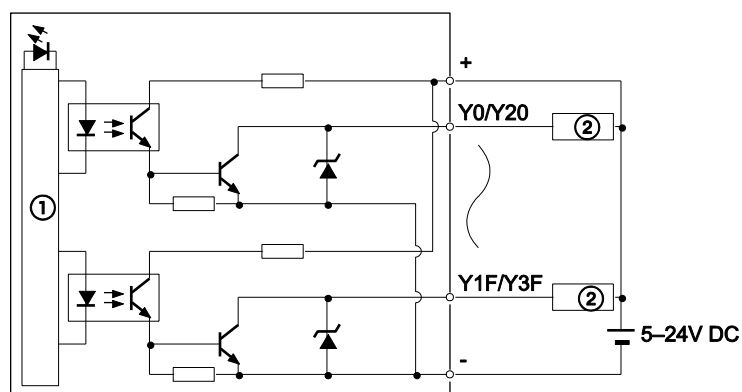

- ① Internal circuit
- ② Load

Restrictions on load current

Refer to the following figure and reduce the load current according to the external power supply voltage.

Y0–Y7, 0.3A/output:

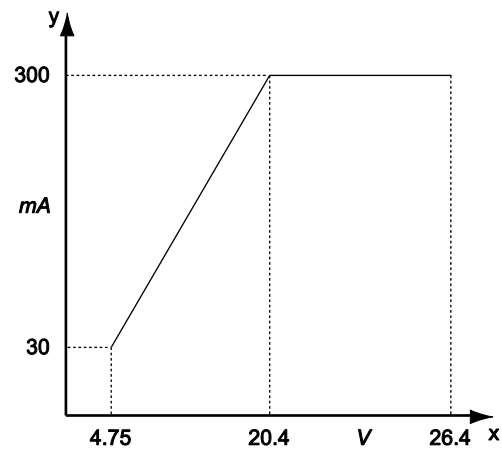

x External power supply voltage

y Max. load current

Any other output, 0.1A/output:

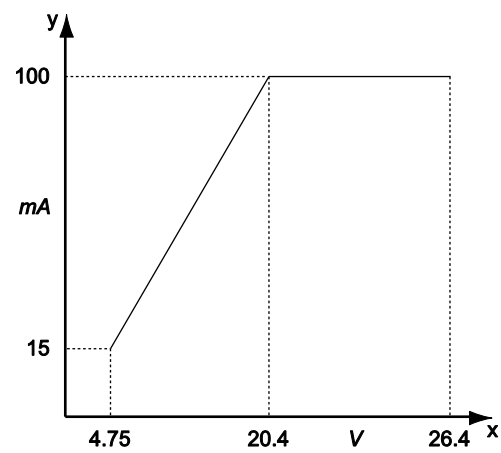

x External power supply voltage

y Max. load current

Terminal layout

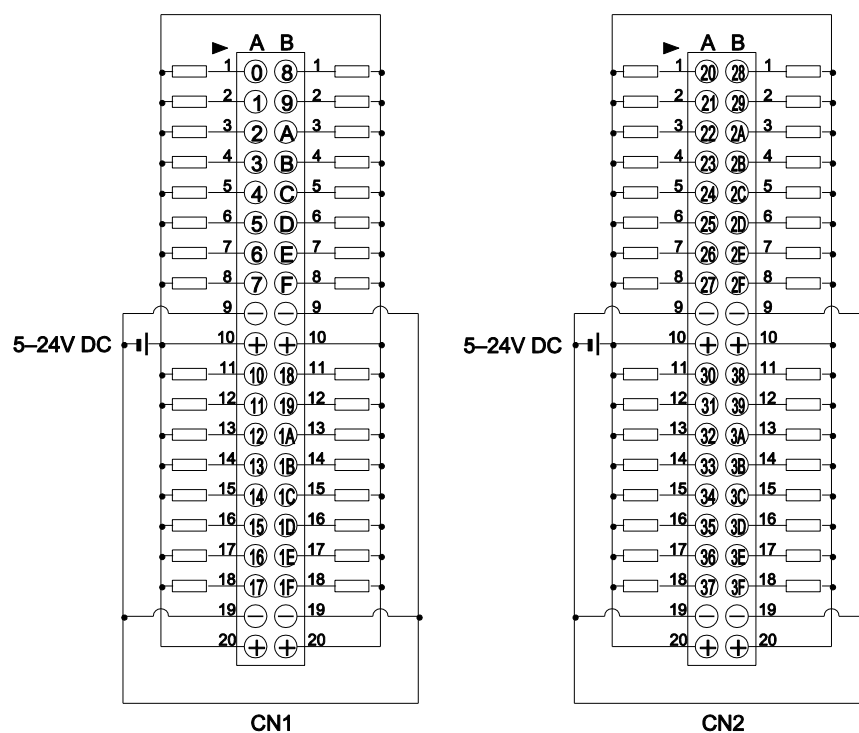

Although the positive and negative terminals are connected internally, connect these terminals externally as well.

2.4.7 64 source (PNP) outputs (AFP7Y64P)

Item	Description	
Insulation method	Optical coupler	
Output type	Open collector	
Rated load voltage	5-24V DC	
Operating load voltage range	4.75-26.4V DC	
Max. load current	Y0-Y7	0.3A/output (20.4-26.4V DC) and 30mA/output (4.75V DC) (max. 3.2A/common)
	Any other output	0.1A/output (20.4-26.4V DC) and 15mA/output (4.75V DC) (max. 3.2A/common)
Max. inrush current	0.6A	
OFF state leakage current	≤1μA	
ON state voltage drop	≤0.5V	
Response time	FALSE → TRUE	≤0.1ms (load current: ≥2mA)
	TRUE → FALSE	≤0.5ms (load current: ≥2mA)
External power supply	Voltage	4.75-26.4V DC
	Current	90mA/common (at 24V DC)
Surge absorber	Zener diode	
Short circuit protection	-	
Outputs per common	32	

Item	Description
Operation indicator	32-point LED indicator (lit in ON state)
Connection	40-pin MIL connector x2
Weight	≈115g

Outputs that are TRUE simultaneously

Keep the number of outputs per common which are simultaneously TRUE within the following range as determined by the ambient temperature.

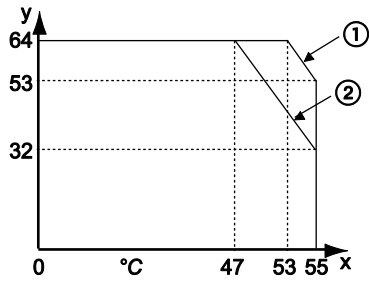

x	Ambient temperature
y	Number of outputs per common that are TRUE simultaneously
①	At 24V DC
②	At 26.4V DC

Internal circuit diagram

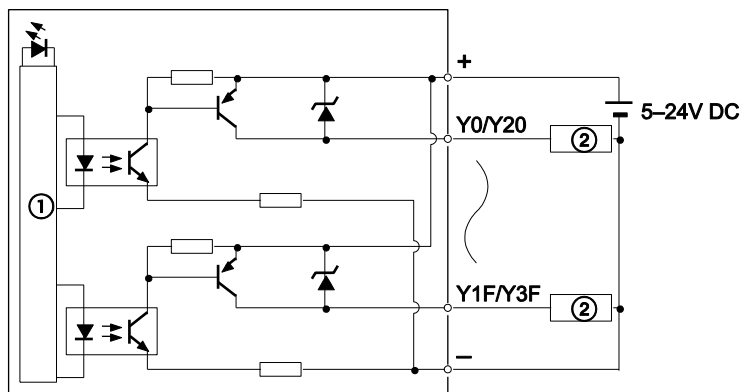

①	Internal circuit
②	Load

Restrictions on load current

Refer to the following figure and reduce the load current according to the external power supply voltage.

Y0–Y7, 0.3A/output:

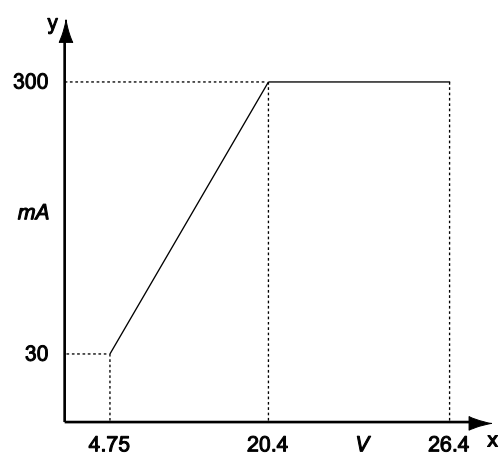

x External power supply voltage

y Max. load current

Any other output, 0.1A/output:

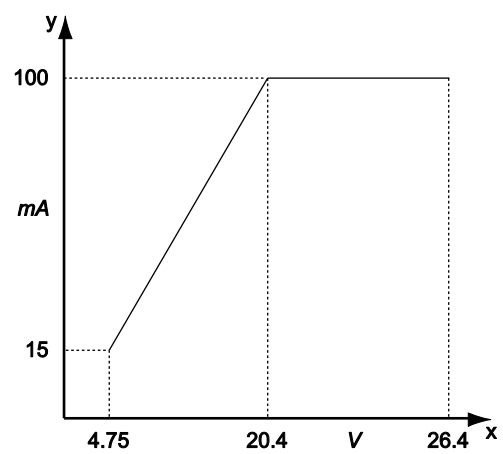

x External power supply voltage

y Max. load current

Terminal layout

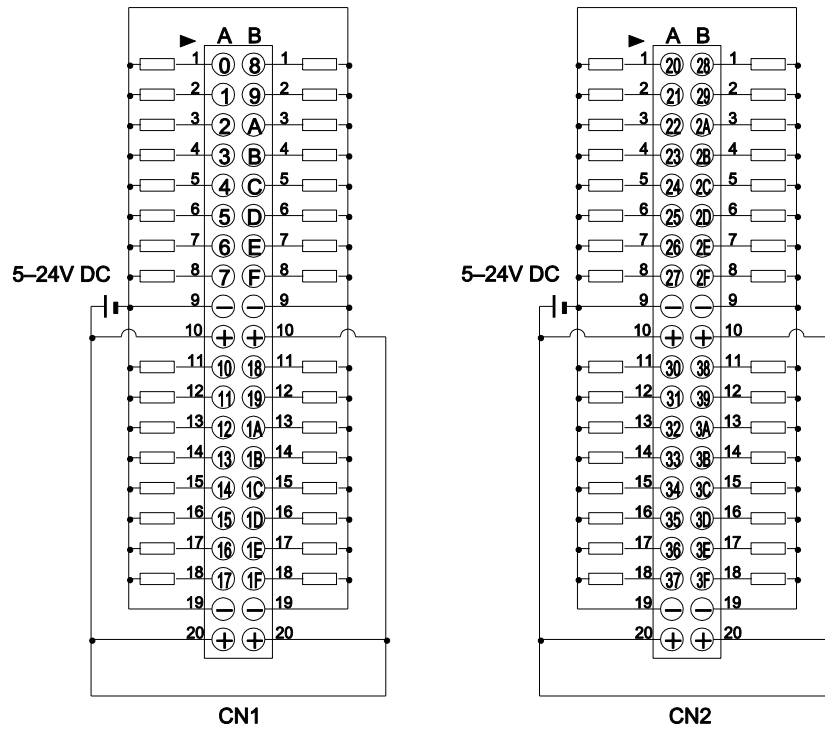

Although the positive and negative terminals are connected internally, connect these terminals externally as well.

2.5 Mixed I/O unit specifications

2.5.1 32 inputs/32 sink (NPN) outputs (AFP7XY64D2T)

	Item	Description	
Input	Insulation method	Optical coupler	
	Rated input voltage	24V DC	
	Rated input current	≈2.7mA (at 24V DC)	
	Input impedance	≈8.2kΩ	
	Operating voltage range	20.4–26.4V DC	
	Min. ON voltage/min. ON current	19.2V DC/2.5mA	
	Max. OFF voltage/max. OFF current	5V DC/1.5mA	
	Response time	FALSE → TRUE	≤0.2ms (input time constant configurable)
		TRUE → FALSE	≤0.2ms (input time constant configurable)
	Input points per common	32	
Output	Insulation method	Optical coupler	
	Output type	Open collector	
	Rated load voltage	5–24V DC	
	Operating load voltage range	4.75–26.4V DC	
	Max. load current	Y0–Y7	0.3A/output (20.4–26.4V DC) and 30mA/output (4.75V DC) (max. 3.2A/common)
		Any other output	0.1A/output (20.4–26.4V DC) and 15mA/output (4.75V DC) (max. 3.2A/common)
	Max. inrush current	0.6A	
	OFF state leakage current	≤1μA	
	ON state voltage drop	≤0.5V	
	Response time	FALSE → TRUE	≤0.1ms (load current: ≥2mA)
		TRUE → FALSE	≤0.3ms (load current: ≥2mA)
	External power supply	Voltage	4.75–26.4V DC
		Current	70mA/common (at 24V DC)
	Surge absorber	Zener diode	
	Short circuit protection	–	
Outputs per common	32		
Operation indicator	32-point LED indicator (lit in ON state)		
Connection	40-pin MIL connector x2		
Weight	≈115g		

Inputs/outputs that are TRUE simultaneously

Keep the number of inputs/outputs per common which are simultaneously TRUE within the following range as determined by the ambient temperature.

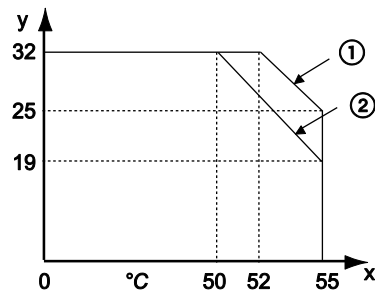

x	Ambient temperature
y	Number of inputs/outputs per common that are TRUE simultaneously
①	At 24V DC
②	At 26.4V DC

Internal circuit diagram

Input:

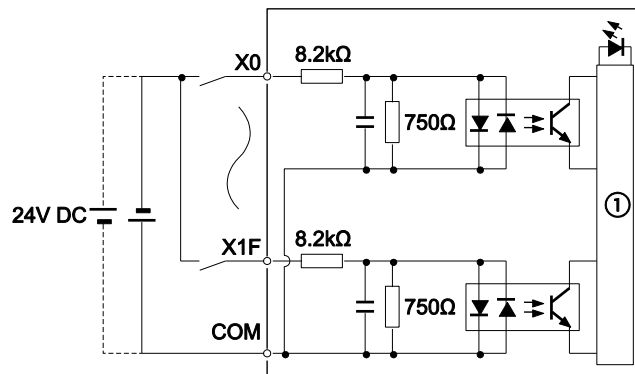

① Internal circuit

Output:

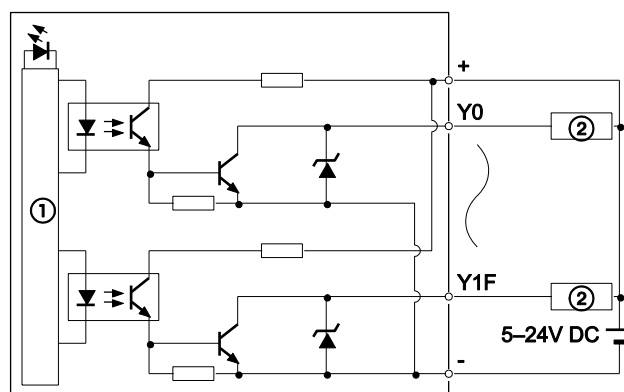

- ① Internal circuit
- ② Load

Restrictions on load current

Refer to the following figure and reduce the load current according to the external power supply voltage.

Y0–Y7, 0.3A/output:

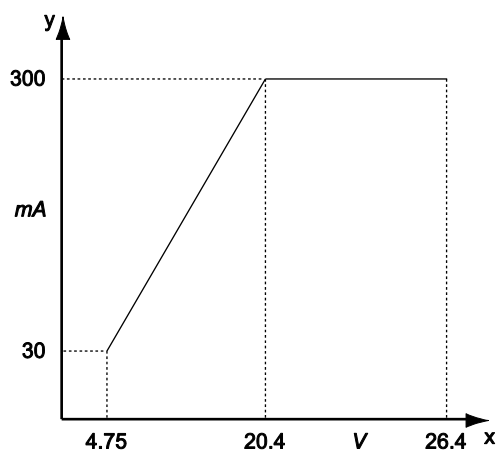

- x External power supply voltage
- y Max. load current

Any other output, 0.1A/output:

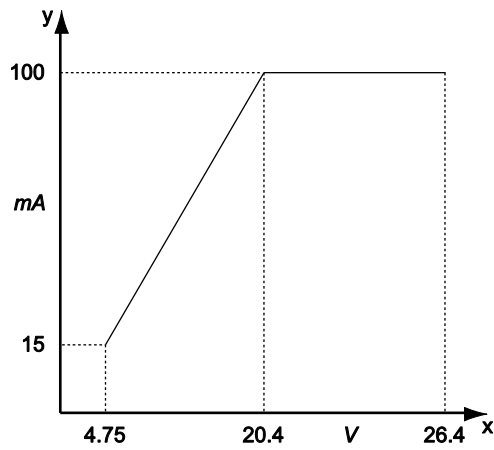

- x External power supply voltage
- y Max. load current

Terminal layout

Input:

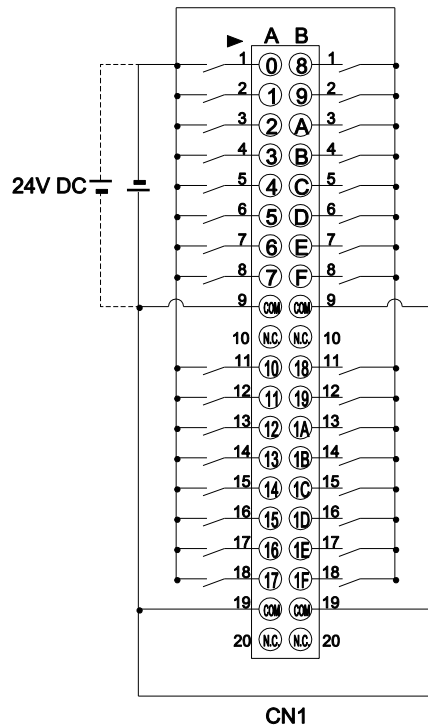

The COM terminals of the input circuits are connected internally.

Output:

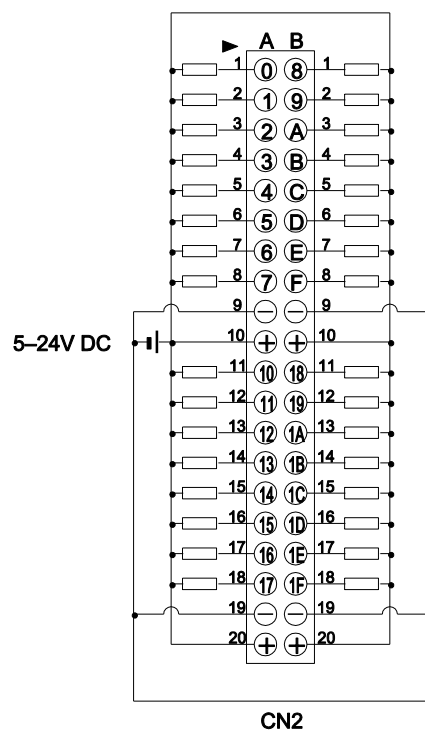

Although the positive and negative terminals are connected internally, connect these terminals externally as well.

2.5.2 32 inputs/32 source (PNP) outputs (AFP7XY64D2P)

	Item	Description	
Input	Insulation method	Optical coupler	
	Rated input voltage	24V DC	
	Rated input current	≈3.4A (at 24V DC)	
	Input impedance	≈7.5kΩ	
	Operating voltage range	20.4–26.4V DC	
	Min. ON voltage/min. ON current	19.2V DC/2.5mA	
	Max. OFF voltage/max. OFF current	5V DC/1.5mA	
	Response time	FALSE → TRUE	≤0.2ms (input time constant configurable)
		TRUE → FALSE	≤0.2ms (input time constant configurable)
	Input points per common	32	
Output	Insulation method	Optical coupler	
	Output type	Open collector	
	Rated load voltage	5–24V DC	
	Operating load voltage range	4.75–26.4V DC	
	Max. load current	Y0–Y7	0.3A/output (20.4–26.4V DC) and 30mA/output (4.75V DC) (max. 3.2A/common)
		Any other output	0.1A/output (20.4–26.4V DC) and 15mA/output (4.75V DC) (max. 3.2A/common)
	Max. inrush current	0.6A	
	OFF state leakage current	≤1μA	
	ON state voltage drop	≤0.5V	
	Response time	FALSE → TRUE	≤0.1ms (load current: ≥2mA)
		TRUE → FALSE	≤0.5ms (load current: ≥2mA)
	External power supply	Voltage	4.75–26.4V DC
		Current	90mA/common (at 24V DC)
	Surge absorber	Zener diode	
	Short circuit protection	–	
		Outputs per common	32
	Operation indicator	32-point LED indicator (lit in ON state)	
	Connection	40-pin MIL connector x2	
	Weight	≈115g	

Inputs/outputs that are TRUE simultaneously

Keep the number of inputs/outputs per common which are simultaneously TRUE within the following range as determined by the ambient temperature.

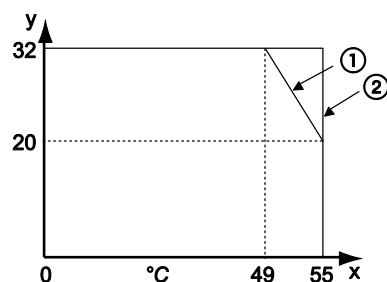

x	Ambient temperature
y	Number of inputs/outputs per common that are TRUE simultaneously
①	At 26.4V DC
②	At 24V DC

Internal circuit diagram

Input:

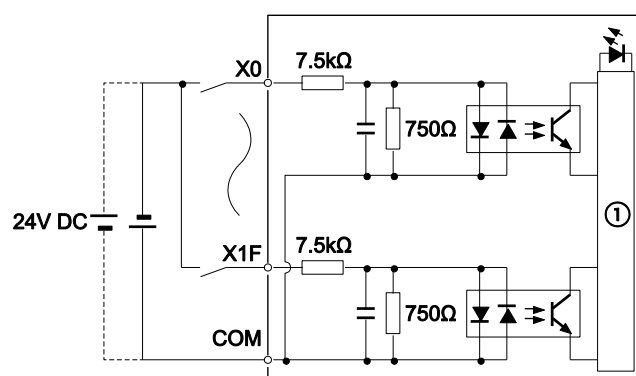

① Internal circuit

Output:

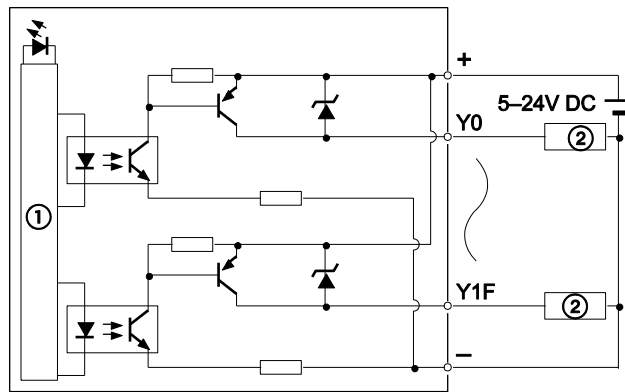

- ① Internal circuit
- ② Load

Restrictions on load current

Refer to the following figure and reduce the load current according to the external power supply voltage.

Y0–Y7, 0.3A/output:

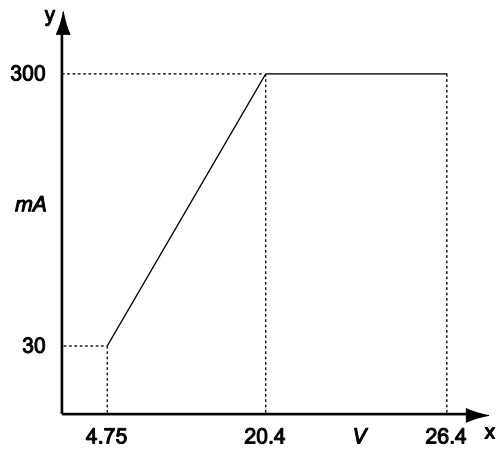

- x External power supply voltage
- y Max. load current

Any other output, 0.1A/output:

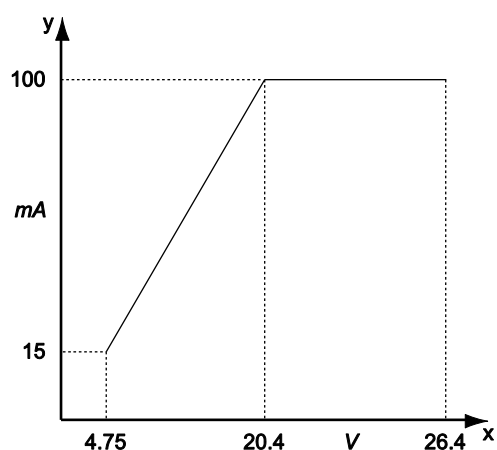

x	External power supply voltage
y	Max. load current

Terminal layout

Input:

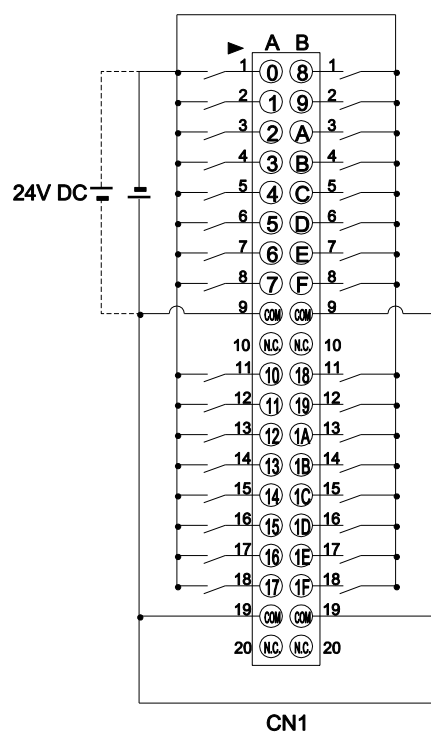

The COM terminals of the input circuits are connected internally.

Output:

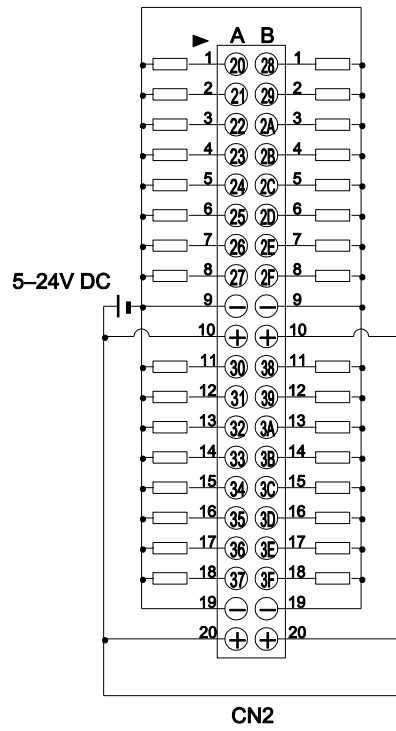

Although the positive and negative terminals are connected internally, connect these terminals externally as well.

2.6 Input time constant setting function

Input time constants for input units or mixed I/O units can be changed as necessary. The selected time constant is added to the hardware-specific response time of the unit.

Procedure

1. Double-click "PLC" in the navigator
2. Double-click "I/O map and unit configuration"
3. Double-click the desired unit type
4. Select a value from the "Input time constant" list box
5. [OK]

Example

DC input unit with 16 inputs

	Hardware-specific response time	Selected input time constant	Resulting response time
FALSE → TRUE	0.1ms	1.0ms	1.1ms
TRUE → FALSE	0.2ms		1.2ms

Error margin

The input time constant has an error margin, which should be kept in mind when selecting a set value. The accuracy of each time constant is shown in the table below.

Set value	Time constant	
	Min.	Max.
No setting	–	–
0.1ms	0.1ms	0.2ms
0.5ms	0.3ms	0.7ms
1ms	0.7ms	1.3ms
5ms	3.0ms	5.2ms
10ms	6.0ms	10.4ms
20ms	12.1ms	20.7ms
70ms	48.6ms	82.8ms

Chapter 3

Wiring

3.1 Before wiring

Before the wiring, carefully confirm the specifications for the units to be wired. Specifically, limitations on the ambient temperature, the number of I/Os that can be TRUE simultaneously, and the supply voltage will differ for different units.

3.2 Input wiring

For connecting input devices see the diagrams and recommendations given below.

3.2.1 Photoelectric and proximity sensors

Relay output type

NPN input:

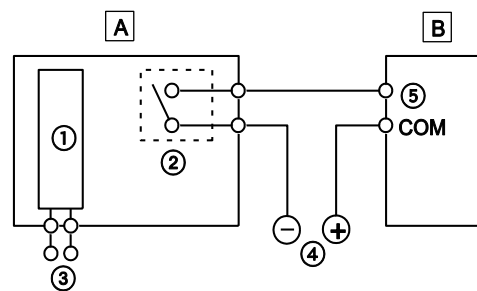

A	Sensor
B	FP7
①	Internal circuit
②	Relay
③	Power supply for sensor
④	Power supply for input
⑤	Input terminal

PNP input:

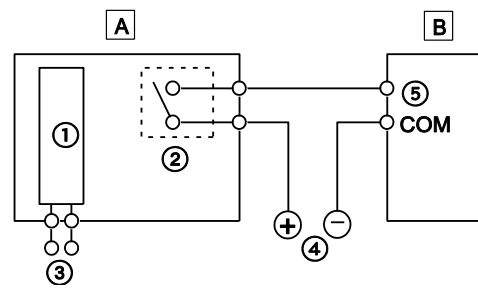

A	Sensor
B	FP7
①	Internal circuit
②	Relay
③	Power supply for sensor
④	Power supply for input
⑤	Input terminal

Open collector output type

NPN output:

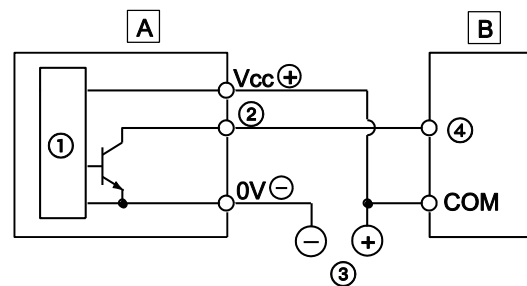

A	Sensor
B	FP7
①	Internal circuit
②	Output
③	Power supply for input
④	Input terminal

PNP output:

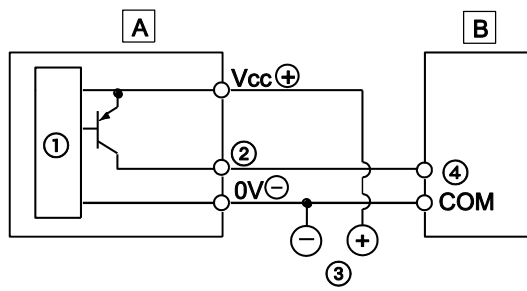

A	Sensor
B	FP7
①	Internal circuit
②	Output
③	Power supply for input
④	Input terminal

Voltage output (universal output) type

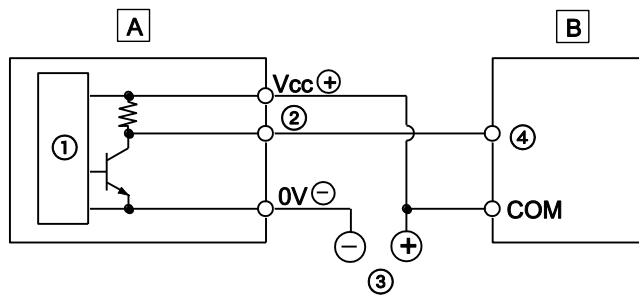

A	Sensor
B	FP7
①	Internal circuit
②	Output
③	Power supply for input
④	Input terminal

Two-wire output type

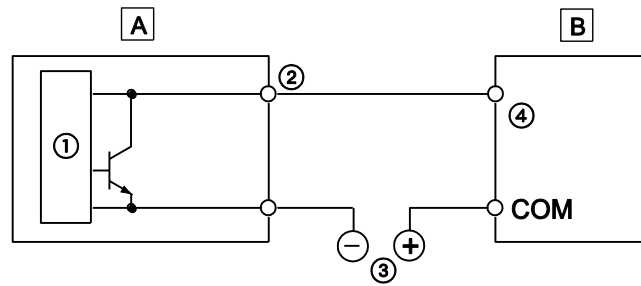

A	Sensor
B	FP7
①	Internal circuit
②	Output
③	Power supply for input
④	Input terminal

3.2.2 Input wiring precautions

When using an LED-equipped Reed switch

When an LED is connected in series to an input contact such as an LED-equipped Reed switch, make sure that the voltage applied to the PLC input terminal is greater than the ON voltage. In particular, take care when connecting a number of switches in series.

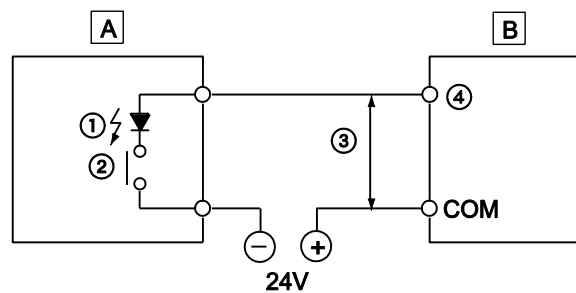

A	LED-equipped Reed switch
B	FP7
①	LED
②	Contact
③	> ON voltage
④	Input terminal

When using a two-wire type sensor

If the input of the PLC does not turn off because of leakage current from the two-wire type sensor (photoelectric sensor or proximity sensor), the use of a bleeder resistor is recommended, as shown below.

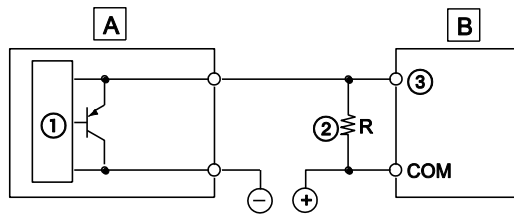

A	Two-wire type sensor
B	FP7
①	Internal circuit
②	Bleeder resistor
③	Input terminal

Using an input unit with 16 inputs (AFP7X16DW):

The OFF voltage of the input is 2.5V. Therefore, select a bleeder resistor value R so that the voltage between the COM terminal and the input terminal will be less than 2.5V. The input impedance is 3.6kΩ.

$$I \times \frac{3.6 \times R}{3.6 + R} \leq 2.5$$

Therefore:

$$R \leq \frac{9}{3.6 \times I - 2.5} \text{ (k}\Omega\text{)}$$

The wattage W of the resistor is:

$$W = \frac{(V)^2}{R}$$

V = Power supply voltage

In the actual selection, use a value that is 3 to 5 times the value of W.

When using an LED-equipped limit switch

If the input of the PLC does not turn off because of the leakage current from the LED-equipped limit switch, the use of a bleeder resistor is recommended, as shown below.

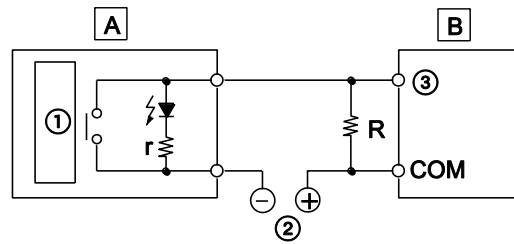

A	LED-equipped limit switch
B	FP7
r	Internal resistor of limit switch (kΩ)
R	Bleeder resistor (kΩ)
①	Internal circuit
②	Power supply for input
③	Input terminal

Using an input unit with 16 inputs (AFP7X16DW):

The OFF voltage of the input is 2.5V. Therefore, when the power supply is 24V, select the bleeder resistor R so that the current will be greater than the result of this formula:

$$I = \frac{24 - 2.5}{r}$$

The input impedance is 3.6kΩ. The resistance R of the bleeder resistor is:

$$R \leq \frac{9}{3.6 \times 1 - 2.5} \text{ (k}\Omega\text{)}$$

The wattage W of the resistor is:

$$W = \frac{(V)^2}{R}$$

V = Power supply voltage

In the actual selection, use a value that is 3 to 5 times the value of W.

3.3 Output wiring

3.3.1 Protective circuit for inductive loads

With an inductive load, a protective circuit should be installed in parallel with the load.

When switching DC inductive loads with the relay output type, be sure to connect a diode across the ends of the load.

Using an AC inductive load (relay output type)

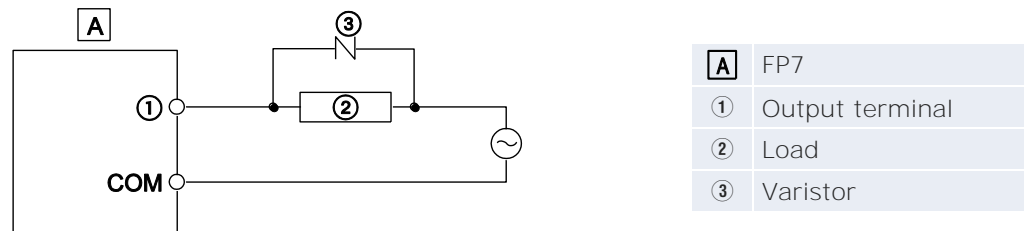
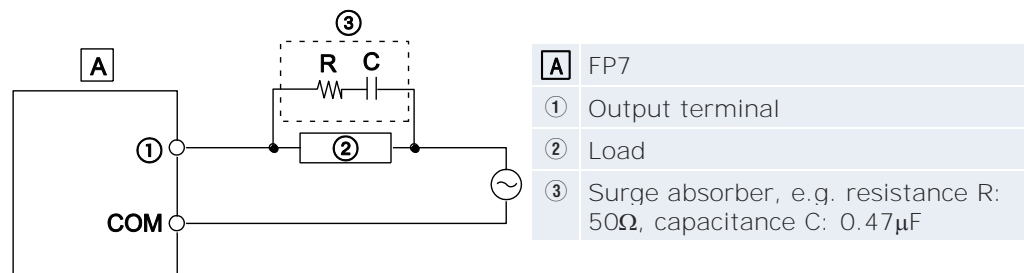

Using a DC inductive load

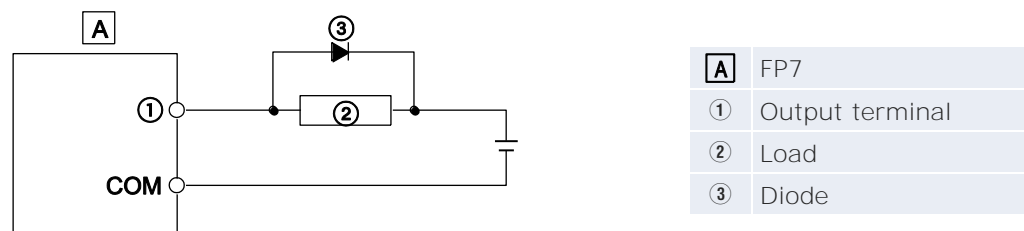

3.3.2 Protective circuit for capacitive loads

When connecting loads with large inrush currents, connect a protection circuit as shown below to minimize their effect.

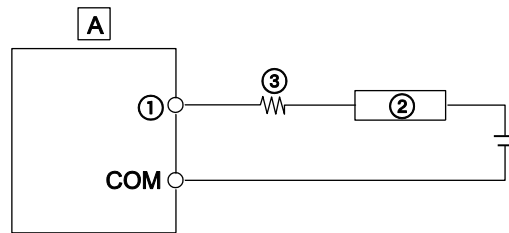

A	FP7
①	Output terminal
②	Load
③	Resistor

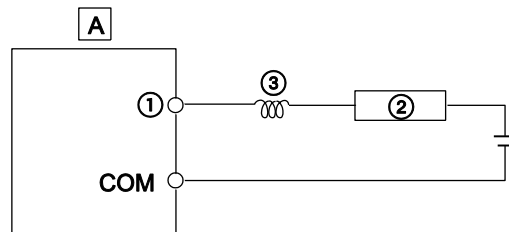

A	FP7
①	Output terminal
②	Load
③	Inductor

3.3.3 Overload protection

There is no fuse in the output circuit. It is recommended to install external fuses in every circuit to reduce the risk of burning out the output circuit when the output is shorted.

There are times that the elements for the output units cannot be protected even if external fuses are connected.

3.3.4 Grounding of AFP7Y16R

If necessary, ground the instrument to increase the noise resistance.

- Be sure to ground the relay output unit AFP7Y16R (see p. 18) to avoid the effects of noise.
- The grounding connection should have a resistance of 100Ω or less.
- The point of grounding should be as close to the PLC as possible. The ground wire should be as short as possible.
- Always use an exclusive ground for PLCs and other devices. If two devices share a single ground point, it may produce an adverse effect.

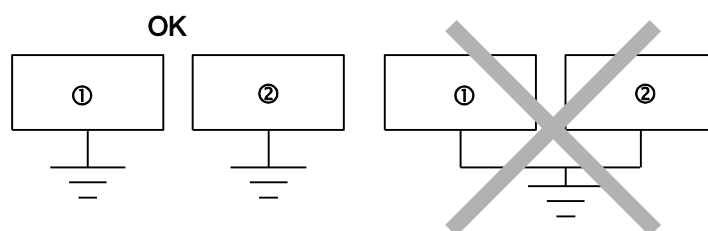

①	PLC
②	Other device (inverter etc.)

3.4 Wiring the terminal block

Suitable wire

Size	Cross-sectional area [mm ²]	Tightening torque [Nm]
AWG22-14	0.3-2.0	0.5-0.6

Wiring method

Remove the terminal block to facilitate wiring.

Procedure

1. Push down release lever
2. Pull off terminal block

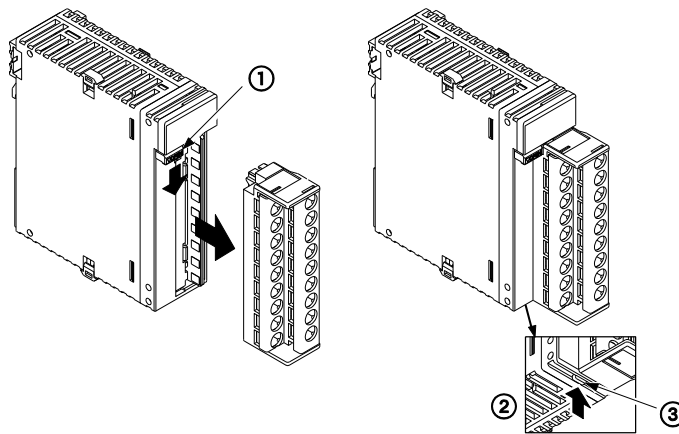

- | | |
|---|------------------------------|
| ① | Terminal block release lever |
| ② | Bottom of unit |
| ③ | Lock button |

Note

To reattach the terminal block, insert it all the way to its original position and press the lock button on the bottom of the unit. Then confirm that the terminal block is securely attached and cannot be removed.

3.5 Wiring the MIL connector

3.5.1 Connectors for wire-pressed terminal cables

This connector is provided with the unit. It allows loose wires to be connected without removing the wire's insulation. A dedicated pressure connection tool is required.

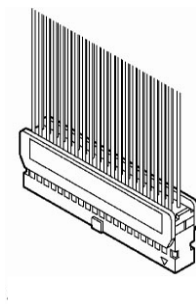

Connector for wire pressed terminal cables (40 pins)

Suitable wire (strand wire)

Size	Cross-sectional area [mm ²]	Insulation thickness [mm]	Rated current
AWG22	0.3	Ø 1.5–1.1	3A
AWG24	0.2		

Connector sets provided with the unit

Manufacturer	Product name	Unit type and required quantity	
		32-point-type unit	64-point-type unit/ Mixed I/O unit
Panasonic	Housing (40 pins)	1 × 1 set	1 × 2 sets
	Semi-cover (40 pins)	2 × 1 set	2 × 2 sets
	Contact (for AWG22 or 24) 5 pins	8 × 1 set	8 × 2 sets

Note

Units with 32 I/Os are provided with one set, units with 64 I/Os and mixed I/O units are provided with two sets each. If you need more connectors, purchase AFP2801 (2 sets/pack).

Pressure connection tool (AXY52000FP)

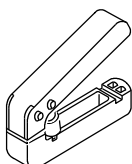

Wiring method

The wire end can be directly crimped without removing the wire's insulation, saving labor.

Procedure

1. Bend the contact back from the carrier and set it in the pressure connection tool

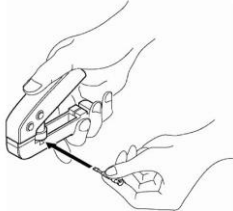

2. Insert wire without removing its insulation until it stops
3. Lightly grip tool

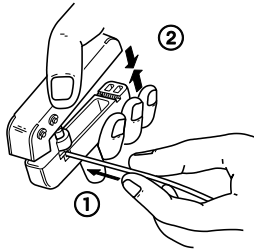

4. Insert press-fitted wire into connector housing

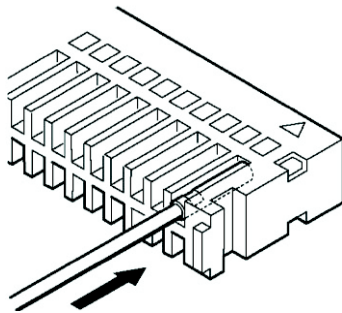

5. When all wires have been inserted, fit semi-cover into place

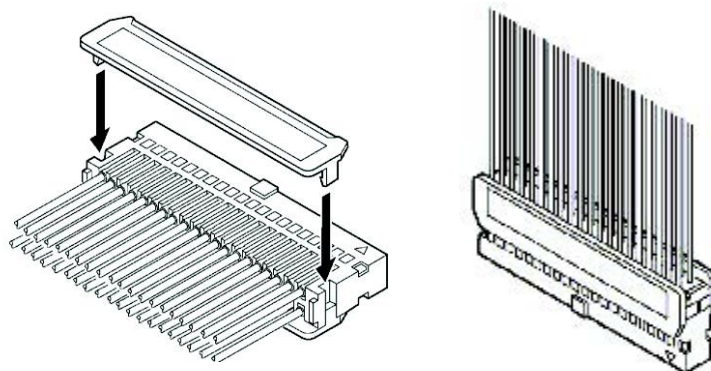
**Note**

If there is a wiring mistake or the cable is incorrectly pressure-connected, the contact puller pin provided with the fitting can be used to remove the contact.

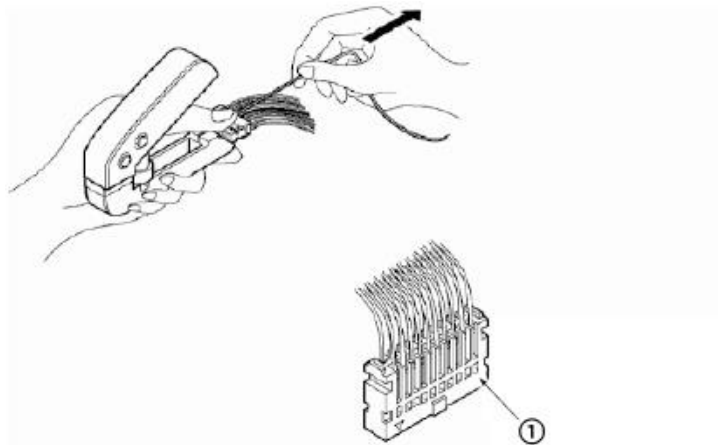

① Press the housing against the pressure connection tool so that the contact puller pin comes in contact with this section.

3.5.2 Flat cable connectors

The relationship between the cable number of flat cable connectors and I/O addresses is shown below.

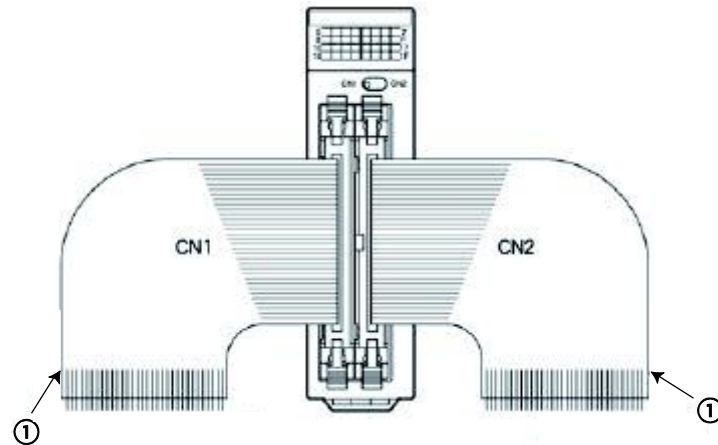

Connection diagram for units with 64 inputs or outputs and for mixed I/O units

① Cable no. 1

Connector 1 (CN1)

Cable no.	Input no.	Output no.	Cable no.	Input no.	Output no.
1	X0	Y0	21	X10	Y10
2	X8	Y8	22	X18	Y18
3	X1	Y1	23	X11	Y11
4	X9	Y9	24	X19	Y19
5	X2	Y2	25	X12	Y12
6	XA	Y6	26	X1A	Y1A
7	X3	Y3	27	X13	Y13
8	XB	YB	28	X1B	Y1B
9	X4	Y4	29	X14	Y14
10	XC	YC	30	X1C	Y1C
11	X5	Y5	31	X15	Y15
12	XD	YD	32	X1D	Y1D
13	X6	Y6	33	X16	Y16
14	XE	YE	34	X1E	Y1E
15	X7	Y7	35	X17	Y17
16	XF	YF	36	X1F	Y1F
17	COM	–	37	COM	–
18	COM	–	38	COM	–
19	NC	+	39	NC	+
20	NC	+	40	NC	+

Connector 2 (CN2)

Cable no.	Input no.	Output no.	Cable no.	Input no.	Output no.
1	X20	Y20	21	X30	Y30
2	X28	Y28	22	X38	Y38
3	X21	Y21	23	X31	Y31
4	X29	Y29	24	X39	Y39
5	X22	Y22	25	X32	Y32
6	X2A	Y26	26	X3A	Y3A
7	X23	Y23	27	X33	Y33
8	X2B	Y2B	28	X3B	Y3B
9	X24	Y24	29	X34	Y34
10	X2C	Y2C	30	X3C	Y3C
11	X25	Y25	31	X35	Y35
12	X2D	Y2D	32	X3D	Y3D
13	X26	Y26	33	X36	Y36
14	X2E	Y2E	34	X3E	Y3E
15	X27	Y27	35	X37	X37
16	X2F	Y2F	36	X3F	Y3F
17	COM	–	37	COM	–
18	COM	–	38	COM	–
19	NC	+	39	NC	+
20	NC	+	40	NC	+

Suitable wire (strand wire)

Size	Pitch	Rated current
AWG28 (7 wires/Ø 0.127)	1.27mm	1A

North America

Europe

Asia Pacific

China

Japan

Panasonic Electric Works

Please contact our Global Sales Companies in:

Europe

▶ Headquarters	Panasonic Electric Works Europe AG	Rudolf-Diesel-Ring 2, 83607 Holzkirchen, Tel. +49 (0) 8024 648-0, Fax +49 (0) 8024 648-111, www.panasonic-electric-works.com
▶ Austria	Panasonic Electric Works Austria GmbH	Josef Madersperger Str. 2, 2362 Biedermannsdorf, Tel. +43 (0) 2236-26846, Fax +43 (0) 2236-46133 www.panasonic-electric-works.at
	Panasonic Industrial Devices Materials Europe GmbH	Ennschafenstraße 30, 4470 Enns, Tel. +43 (0) 7223 883, Fax +43 (0) 7223 88333, www.panasonic-electronic-materials.com
▶ Benelux	Panasonic Electric Works Sales Western Europe B.V.	De Rijn 4, (Postbus 211), 5684 PJ Best, (5680 AE Best), Netherlands, Tel. +31 (0) 499 372727, Fax +31 (0) 499 372185, www.panasonic-electric-works.nl
▶ Czech Republic	Panasonic Electric Works Europe AG	Administrative centre PLATINIUM, Veverí 3163/111, 616 00 Brno, Tel. +420 541 217 001, Fax +420 541 217 101, www.panasonic-electric-works.cz
▶ France	Panasonic Electric Works Sales Western Europe B.V.	Succursale française, 10, rue des petits ruisseaux, 91370 Verrières Le Buisson, Tél. +33 (0) 1 6013 5757, Fax +33 (0) 1 6013 5758, www.panasonic-electric-works.fr
▶ Germany	Panasonic Electric Works Europe AG	Rudolf-Diesel-Ring 2, 83607 Holzkirchen, Tel. +49 (0) 8024 648-0, Fax +49 (0) 8024 648-111, www.panasonic-electric-works.de
▶ Hungary	Panasonic Electric Works Europe AG	Magyarországi Közvetlen Kereskedelmi Képviselet, 1117 Budapest, Neumann János u. 1., Tel. +36 1 999 89 26 www.panasonic-electric-works.hu
▶ Ireland	Panasonic Electric Works UK Ltd.	Irish Branch Office, Dublin, Tel. +353 (0) 14600969, Fax +353 (0) 14601131, www.panasonic-electric-works.co.uk
▶ Italy	Panasonic Electric Works Italia srl	Via del Commercio 3-5 (Z.I. Ferlina), 37012 Bussolengo (VR), Tel. +39 0456752711, Fax +39 0456700444, www.panasonic-electric-works.it
▶ Nordic Countries	Panasonic Electric Works Europe AG Panasonic Eco Solutions Nordic AB	Filial Nordic, Knarrarnäsgatan 15, 164 40 Kista, Sweden, Tel. +46 859476680, Fax +46 859476690, www.panasonic-electric-works.se
▶ Poland	Panasonic Electric Works Polska sp. z o.o	Jungmansgatan 12, 21119 Malmö, Tel. +46 40 697 7000, Fax +46 40 697 7099, www.panasonic-fire-security.com
▶ Spain	Panasonic Electric Works España S.A.	ul. Wołoska 9A, 02-583 Warszawa, Tel. +48 22 338-11-33, Fax +48 22 338-12-00, www.panasonic-electric-works.pl
▶ Switzerland	Panasonic Electric Works Schweiz AG	Barajas Park, San Severo 20, 28042 Madrid, Tel. +34 913293875, Fax +34 913292976, www.panasonic-electric-works.es
▶ United Kingdom	Panasonic Electric Works UK Ltd.	Grundstrasse 8, 6343 Rotkreuz, Tel. +41 (0) 41 7997050, Fax +41 (0) 41 7997055, www.panasonic-electric-works.ch
		Sunrise Parkway, Linford Wood, Milton Keynes, MK14 6LF, Tel. +44 (0) 1908 231555, Fax +44 (0) 1908 231599, www.panasonic-electric-works.co.uk

North & South America

▶ USA	Panasonic Industrial Devices Sales Company of America	629 Central Avenue, New Providence, N.J. 07974, Tel. 1-908-464-3550, Fax 1-908-464-8513, www.pewa.panasonic.com
--------------	--------------------------------------------------------------	-------------------------------------------------------------------------------------------------------------------------------------------------------------

Asia Pacific/China/Japan

▶ China	Panasonic Electric Works Sales (China) Co. Ltd.	Level 2, Tower W3, The Towers Oriental Plaza, No. 2, East Chang An Ave., Dong Cheng District, Beijing 100738, Tel. +86-10-5925-5988, Fax +86-10-5925-5973
▶ Hong Kong	Panasonic Industrial Devices Automation Controls Sales (Hong Kong) Co., Ltd.	RM1205-9, 12/F, Tower 2, The Gateway, 25 Canton Road, Tsimshatsui, Kowloon, Hong Kong, Tel. +852-2956-3118, Fax +852-2956-0398
▶ Japan	Panasonic Corporation	1048 Kadoma, Kadoma-shi, Osaka 571-8686, Japan, Tel. +81-6-6908-1050, Fax +81-6-6908-5781, www.panasonic.net
▶ Singapore	Panasonic Industrial Devices Automation Controls Sales Asia Pacific	300 Beach Road, #16-01 The Concourse, Singapore 199555, Tel. +65-6390-3811, Fax +65-6390-3810